

**1. WALL MOUNTED TYPE
ROOM AIR-CONDITIONER
(Split system, Air to air)
heat pump type**

SRK25GZ-L1, SRK35GZ-L1, SRK502Z-L

**1. WALL MOUNTED TYPE
ROOM AIR-CONDITIONER
(Split system, Air to air)
heat pump type**

SRK25GZ-L1, SRK35GZ-L1, SRK502Z-L

CONTENTS

1.1	GENERAL INFORMATION	3
1.1.1	Specific features	3
1.1.2	How to read the model name	3
1.2	SELECTION DATA	4
1.2.1	Specifications	4
1.2.2	Range of usage & limitations	7
1.2.3	Exterior dimensions	8
1.2.4	Piping system	11
1.3	ELECTRICAL DATA	12
1.3.1	Electrical wiring	12
1.4	OUTLINE OF OPERATION CONTROL BY MICROCOMPUTER	16
1.5	APPLICATION DATA	30
1.5.1	Selection of location for installation	31
1.5.2	Installation of indoor unit.....	32
1.5.3	Installation of outdoor unit	34
1.5.4	Refrigerant piping	35
1.5.5	Test run	36
1.5.6	Precautions for wireless remote controller installation and operation	37
1.6	MAINTENANCE DATA	38
1.6.1	Trouble shooting.....	38
1.6.2	Servicing.....	48
1.6.3	Power supply remote operation	49

1.1 GENERAL INFORMATION

1.1.1 Specific features

The “Mitsubishi Daiya” room air-conditioner: SRK series are of split and wall mounted type and the unit consists of indoor unit and outdoor unit with refrigerant precharged in factory. The indoor unit is composed of room air cooling or heating equipment with operation control switch and the outdoor unit is composed of condensing unit with compressor.

(1) Inverter (Frequency converter) for multi-steps power control

- Heating/Cooling

The rotational speed of a compressor is changed in step in relation to varying load, to interlock with the indoor and outdoor unit fans controlled to changes in frequency, thus controlling the power.

- Allowing quick heating/cooling operation during start-up period. Constant room temperature by fine-tuned control after the unit has stabilized.

(2) Fuzzy control

- Fuzzy control calculates the amount of variation in the difference between the suction air temperature and the setting temperature in compliance with the fuzzy rules in order to control the air capacity and the inverter frequency.

(3) Remote control flap

The flap can be automatically controlled by operating wireless remote control.

- Natural flow (AUTO): Flap operation is automatically control.
- Swing: This will swing the flap up and down.
- Memory flap: Once the flap position is set, the unit memorizes the position and continues to operate at the same position from the next time.

(4) Self diagnosis function

- We are constantly trying to do better service to our customers by installing such judges that show abnormality of operation as follows. (See Page 39)

1.1.2 How to read the model name

Example :

SR K 35 GZ - L 1

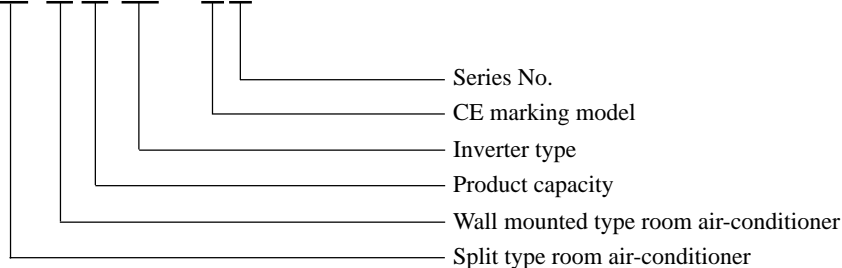

1.2 SELECTION DATA

1.2.1 Specifications

Model SRK25GZ-L1 (Indoor unit)
SRC25GZ-L1 (Outdoor unit)

Item		Model	SRK25GZ-L1	SRC25GZ-L1	
Cooling capacity ⁽¹⁾		W	2500 [900-2900]		
Heating capacity ⁽¹⁾		W	3400 [900-4000]		
Power source			1 Phase, 220/240V, 50Hz		
Operation data ⁽¹⁾	Cooling input	kW	0.96 [0.31-1.22]		
	Running current (Cooling)	A	4.8		
	Heating input	kW	1.17 [0.28-1.35]		
	Running current (Heating)	A	5.8		
	Inrush current	A	5.8		
	COP (In cooling)		2.60		
Noise level		dB (A)	Cooling: 38 Heating: 39	Cooling: 46 Heating: 46	
Exterior dimensions					
Height × Width × Depth		mm	250 × 750 × 178	540 × 645 × 245	
Color			Ivory white	Polar white	
Net weight		kg	7.5	28	
Refrigerant equipment					
Compressor type & Q'ty			-	RM5465GA1 (Rotary type) × 1	
Motor		kW	-	0.75	
Starting method			-	Line starting	
Heat exchanger			Louver fins & bare tubing		
Refrigerant control			Capillary tubes		
Refrigerant ⁽⁴⁾		kg	R22 0.64 (Pre-Charged up to the piping length of 5m)		
Refrigerant oil		ℓ	0.35 (BARREL FREEZE 32SAM)		
Deice control			MC control		
Air handling equipment					
Fan type & Q'ty			Tangential fan × 1	Propeller fan × 1	
Motor		W	18	20	
Air flow (at High)	(Cooling)	CMM	7.0	21	
	(Heating)		7.5	21	
Air filter, Q'ty			Polypropylene net (washable) × 2	-	
Shock & vibration absorber			-	Cushion rubber (for compressor)	
Electric heater			-	-	
Operation control					
Operation switch			Wireless-Remote controller	-	
Room temperature control			MC. Thermostat	-	
Pilot lamp			RUN (Green), TIMER (Yellow)		
Safety equipment			Compressor: Overheat protection, heating overload protection (High pressure control), overcurrent protection, serial signal error protection, indoor fan motor error protection		
Refrigerant piping	O.D	mm (in)	Liquid line: φ6.35 (1/4") Gas line: φ9.52 (3/8")		
	Connecting method		Flare connecting		
	Attached length of piping		Liquid line: 0.4 m Gas line : 0.35 m	-	
	Insulation		Necessary (Both sides)		
Drain hose			Connectable		
Power source cord			2.5 m (3 cores with Earth)		
Connection wiring	Size × Core number		1.5 mm ² × 4 cores (Including earth cable)		
	Connecting method		Terminal block (Screw fixing type)		
Accessories (included)			Mounting kit		
Optional parts			-		

Notes (1) The data are measured at the following conditions.

Operation	Item	Indoor air temperature		Outdoor air temperature		Standards
		DB	WB	DB	WB	
Cooling		27°C	19°C	35°C	24°C	JIS C9612, ISO-T1
		20°C	-	7°C	6°C	JIS C9612, ISO-T1

(2) The values for performance and power consumption shown in brackets [-] indicate the range from minimum to maximum.

(3) The operation data are applied to the 220/240V districts respectively.

(4) Limitation of Voltage application Minimum: 198V Maximum: 264V

(5) The refrigerant quantity to be charged includes the refrigerant in 5 m connecting piping.

(Purging is not required even in the short piping.)

If the piping length is longer,

(When it is 5 to 15 m, add 20 g refrigerant per meter.)

**Model SRK35GZ-L1 (Indoor unit)
SRC35GZ-L1 (Outdoor unit)**

Item		Model	SRK35GZ-L1	SRC35GZ-L1	
Cooling capacity ⁽¹⁾		W	3650 [900-3900]		
Heating capacity ⁽¹⁾		W	4800 [900-6100]		
Power source			1 Phase, 220/240V, 50Hz		
Operation data ⁽¹⁾	Cooling input	kW	1.24 [0.35-1.60]		
	Running current (Cooling)	A	6.3		
	Heating input	kW	1.52 [0.35-2.10]		
	Running current (Heating)	A	7.7		
	Inrush current	A	7.7		
	COP (Cooling)		2.94		
	Noise level	dB (A)	Cooling: 39 Heating: 42	Cooling: 46 Heating: 47	
Exterior dimensions					
Height × Width × Depth		mm	275 × 790 × 174	542 × 795 × 255	
Color			Ivory white	Polar white	
Net weight		kg	8	35	
Refrigerant equipment					
Compressor type & Q'ty			-	RM5485GAE3 [Rotary type] × 1	
Motor		kW	-	0.75	
Starting method			-	Line starting	
Heat exchanger			Louver fins & bare tubing		
Refrigerant control			Capillary tubes		
Refrigerant ⁽⁴⁾		kg	R22 1.1 (Pre-Charged up to the piping length of 5m)		
Refrigerant oil		ℓ	0.35 (BARREL FREEZE 32SAM)		
Deice control			MC control		
Air handling equipment					
Fan type & Q'ty			Tangential fan × 1	Propeller fan × 1	
Motor		W	16	18	
Air flow (at High)	(Cooling)	CMM	7	24	
	(Heating)		10	24	
Air filter, Q'ty			Polypropylene net (washable) × 2	-	
Shock & vibration absorber			-	Cushion rubber (for compressor)	
Electric heater			-	-	
Operation control					
Operation switch			Wireless-Remote controller	-	
Room temperature control			MC. Thermostat	-	
Pilot lamp			RUN (Green), TIMER (Yellow)		
Safety equipment			Compressor: Overheat protection, heating overload protection (High pressure control), overcurrent protection, frosting protection, serial signal error protection, indoor fan motor error protection		
Refrigerant piping	O.D	mm (in)	Liquid line: φ6.35 (1/4") Gas line: φ12.7 (1/2")		
	Connecting method		Flare connecting		
	Attached length of piping		Liquid line: 0.4 m Gas line : 0.35 m	-	
	Insulation		Necessary (Both sides)		
Drain hose			Connectable		
Power source cord			2.5 m (3 cores with Earth)		
Connection wiring	Size × Core number		1.5 mm ² × 4 cores (Including earth cable)		
	Connecting method		Terminal block (Screw fixing type)		
Accessories (included)			Mounting kit		
Optional parts			-		

Notes (1) The data are measured at the following conditions.

Operation	Item	Indoor air temperature		Outdoor air temperature		Standards
		DB	WB	DB	WB	
Cooling		27°C	19°C	35°C	24°C	JIS C9612, ISO-T1
Heating		20°C	-	7°C	6°C	JIS C9612, ISO-T1

(2) The values for performance and power consumption shown in brackets [-] indicate the range from minimum to maximum.

(3) The operation data are applied to the 220/240V districts respectively.

(4) Limitation of Voltage application Minimum: 198V Maximum: 264V

(5) The refrigerant quantity to be charged includes the refrigerant in 5 m connecting piping.

(Purging is not required even in the short piping.)

If the piping length is longer,

(When it is 5 to 15 m, add 20 g refrigerant per meter.)

Model SRK502Z-L (Indoor unit)
SRC502Z-L (Outdoor unit)

Item		Model	SRK502Z-L	SRC502Z-L	
Cooling capacity ⁽¹⁾		W	5000 [900-5600]		
Heating capacity ⁽¹⁾		W	6700 [900-7900]		
Power source			1 Phase, 220/240V, 50Hz		
Operation data ⁽¹⁾	Cooling input	kW	2.22 [0.17-2.65]		
	Running current (Cooling)	A	10.2		
	Heating input	kW	2.50 [0.145-2.55]		
	Running current (Heating)	A	11.5		
	Inrush current	A	11.5		
	COP (Cooling)		2.25		
	Noise level	dB (A)	Cooling: 43 Heating: 43	Cooling: 48 Heating: 48	
Exterior dimensions					
Height × Width × Depth		mm	275 × 790 × 189	595 × 720 × 290	
Color			Ivory white	Polar white	
Net weight		kg	9	36	
Refrigerant equipment					
Compressor type & Q'ty			-	GR5490FD4 [Scroll type] × 1	
Motor		kW	-	1.5	
Starting method			-	Line starting	
Heat exchanger			Louver fins & bare tubing		
Refrigerant control			Electric expansion valve		
Refrigerant ⁽⁴⁾		kg	R22 1.24 (Pre-Charged up to the piping length of 7m)		
Refrigerant oil		ℓ	0.35 (BARREL FREEZE 32SAM)		
Deice control			MC control		
Air handling equipment					
Fan type & Q'ty			Tangential fan × 1	Propeller fan × 1	
Motor		W	26	35	
Air flow (at High)	(Cooling)	CMM	10	26	
	(Heating)		10.5	30	
Air filter, Q'ty			Polypropylene net (washable) × 2	-	
Shock & vibration absorber			-	Cushion rubber (for compressor)	
Electric heater			-	-	
Operation control					
Operation switch			Wireless-Remote controller	-	
Room temperature control			MC. Thermostat	-	
Pilot lamp			RUN (Green), TIMER (Yellow), ECONO (Orange), HI POWER (Green)		
Safety equipment			Compressor: Overheat protection, heating overload protection (High pressure control), overcurrent protection, frosting protection, serial signal error protection, indoor fan motor error protection, Comp. rotor lock		
Refrigerant piping	O.D	mm (in)	Liquid line: φ6.35 (1/4") Gas line: φ12.7 (1/2")		
	Connecting method		Flare connecting		
	Attached length of piping		Liquid line: 0.4 m Gas line : 0.35 m	-	
	Insulation		Necessary (Both sides)		
Drain hose			Connectable		
Power source cord			2.5 m (3 cores with Earth)		
Connection wiring	Size × Core number		1.5 mm ² × 4 cores (Including earth cable)		
	Connecting method		Terminal block (Screw fixing type)		
Accessories (included)			Mounting kit		
Optional parts			-		

Notes (1) The data are measured at the following conditions.

Operation	Item	Indoor air temperature		Outdoor air temperature		Standards
		DB	WB	DB	WB	
Cooling		27°C	19°C	35°C	24°C	JIS C9612, ISO-T1
Heating		20°C	-	7°C	6°C	JIS C9612, ISO-T1

(2) The values for performance and power consumption shown in brackets [-] indicate the range from minimum to maximum.

(3) The operation data are applied to the 220/240V districts respectively.

(4) Limitation of Voltage application Minimum: 198V Maximum: 264V

(5) The refrigerant quantity to be charged includes the refrigerant in 7 m connecting piping.

(Purging is not required even in the short piping.)

If the piping length is longer,

(When it is 7 to 25 m, add 20 g refrigerant per meter.)

1.2.2 Range of usage & limitations

(1) Inlet air temperature

(a) Cooling operation

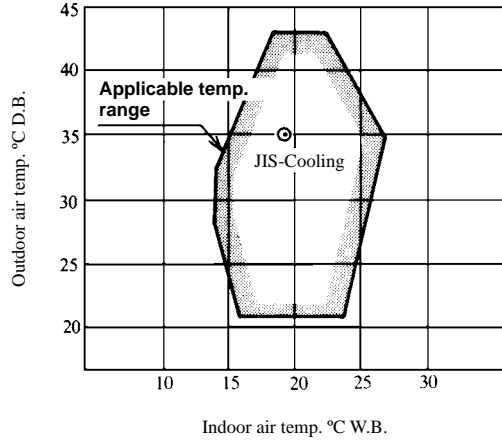

Note: The chart is the result from the continuous operation under constant air temperature conditions, however, excludes the initial pull-down stage.

(b) Heating operation

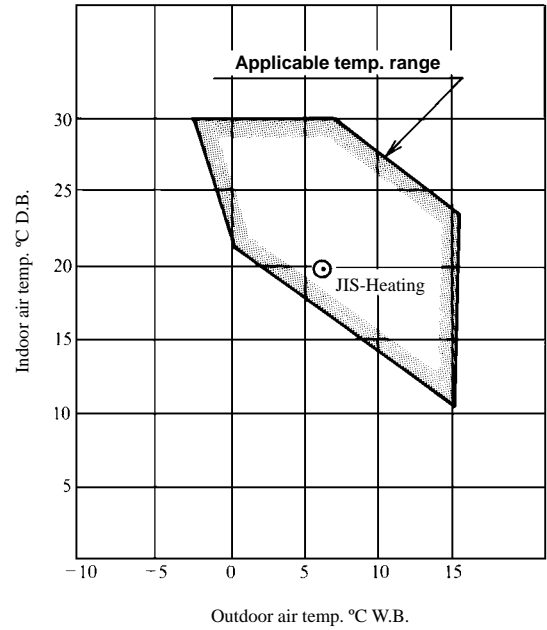

Note: The chart is the result from the continuous operation under constant air temperature conditions, however, excludes the initial pull-down stage and any possible defrost cycles.

(2) Total one way piping length and vertical height difference.

Item		Model	SRK25GZ-L1 SRK35GZ-L1	SRK502Z-L
		Total one way piping length (m)		15
Vertical height difference (m)	Outdoor unit is higher		5	15
	Outdoor unit is lower		5	15

(3) Voltage application

Item	Model	All models
	Maximum (V)	
Maximum (V)		264

1.2.3 Exterior dimensions

(1) Indoor unit Model SRK25GZ-L1

Unit: mm

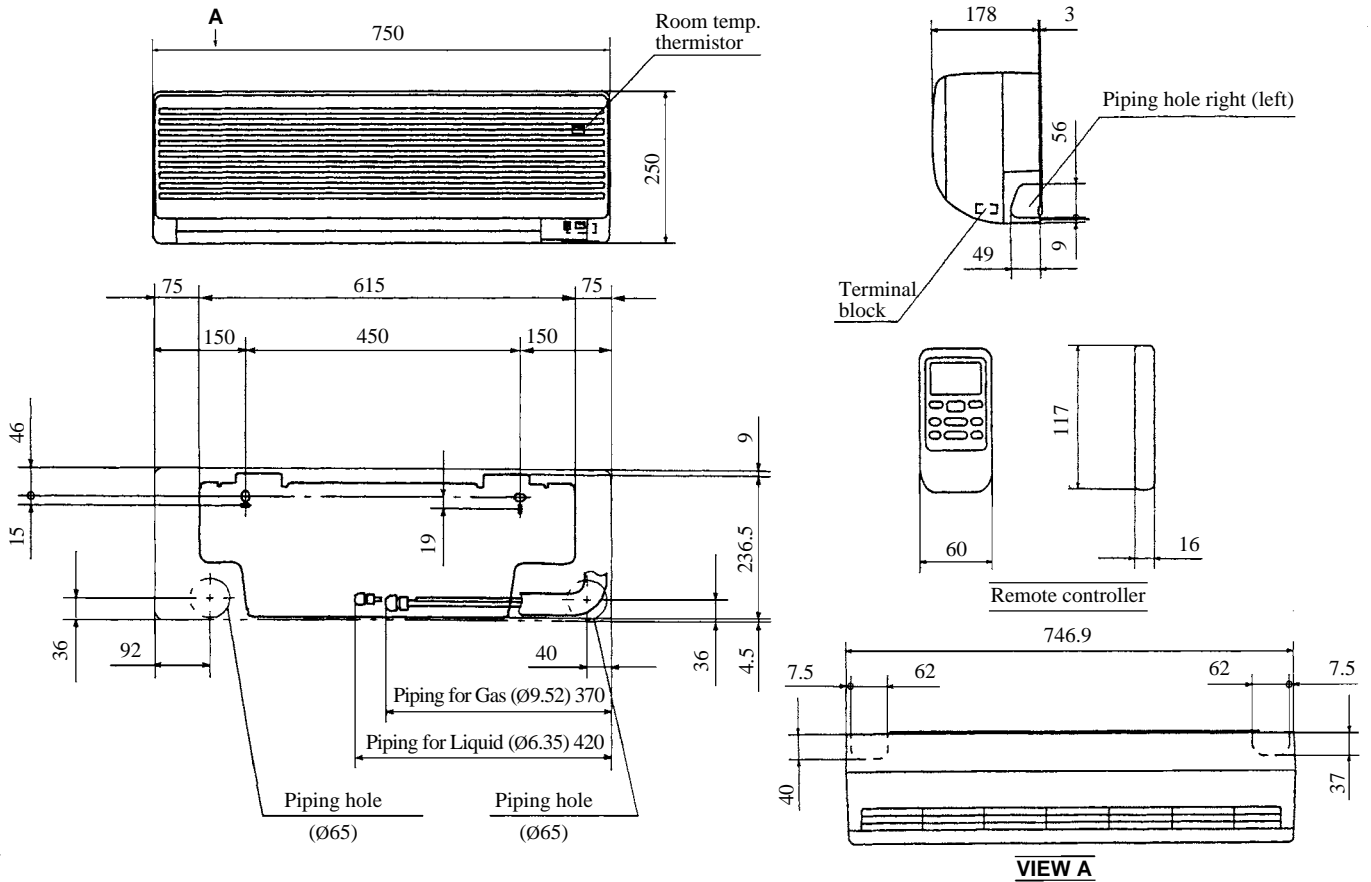

Model SRK35GZ-L1

Unit: mm

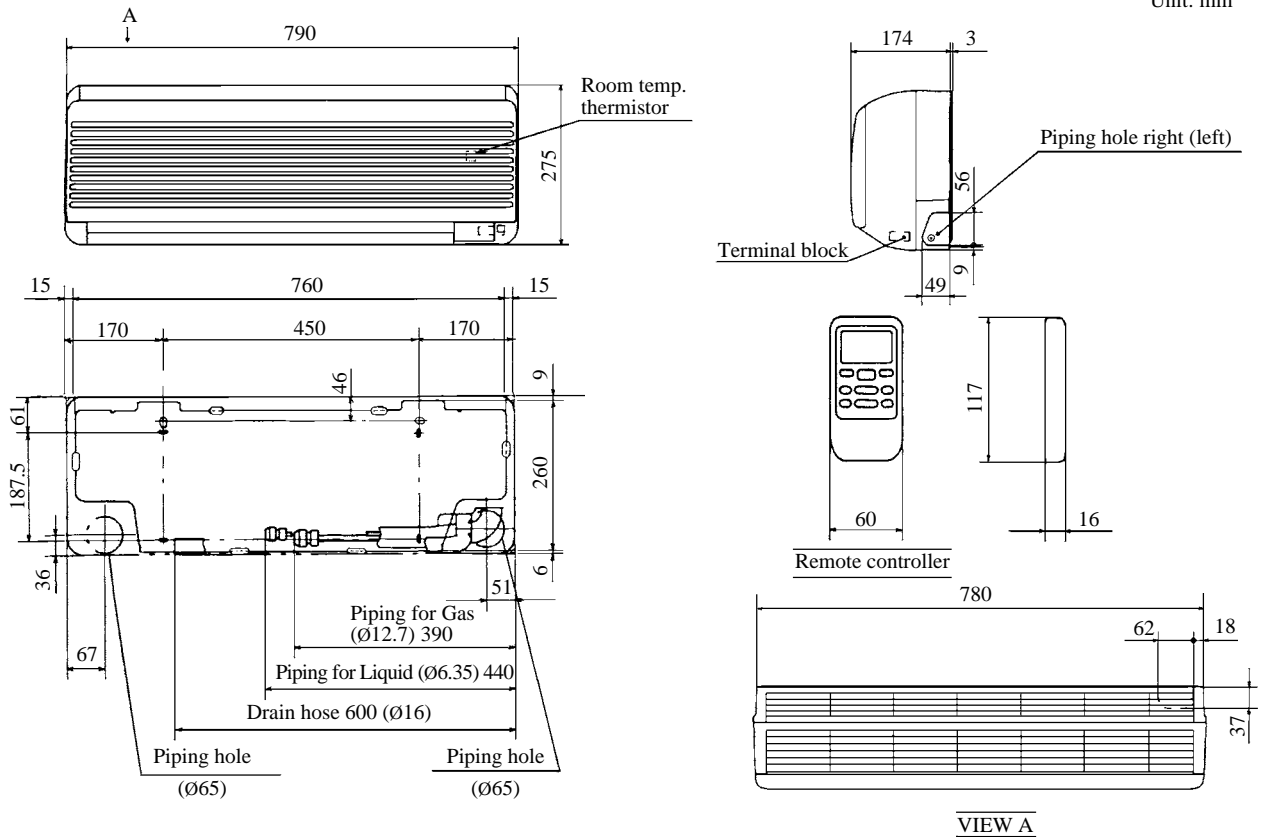

Model SRK502Z-L

Unit: mm

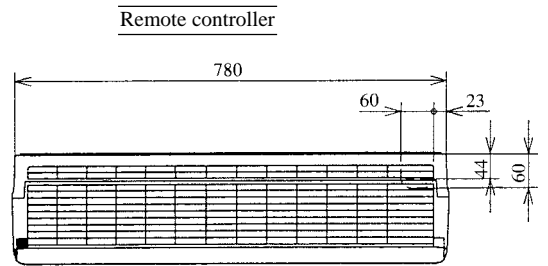
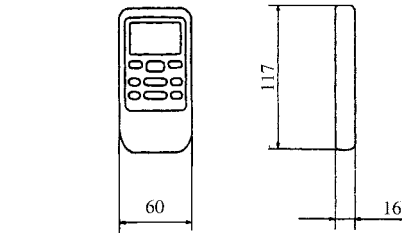
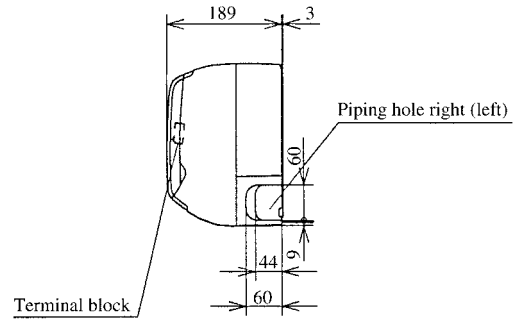
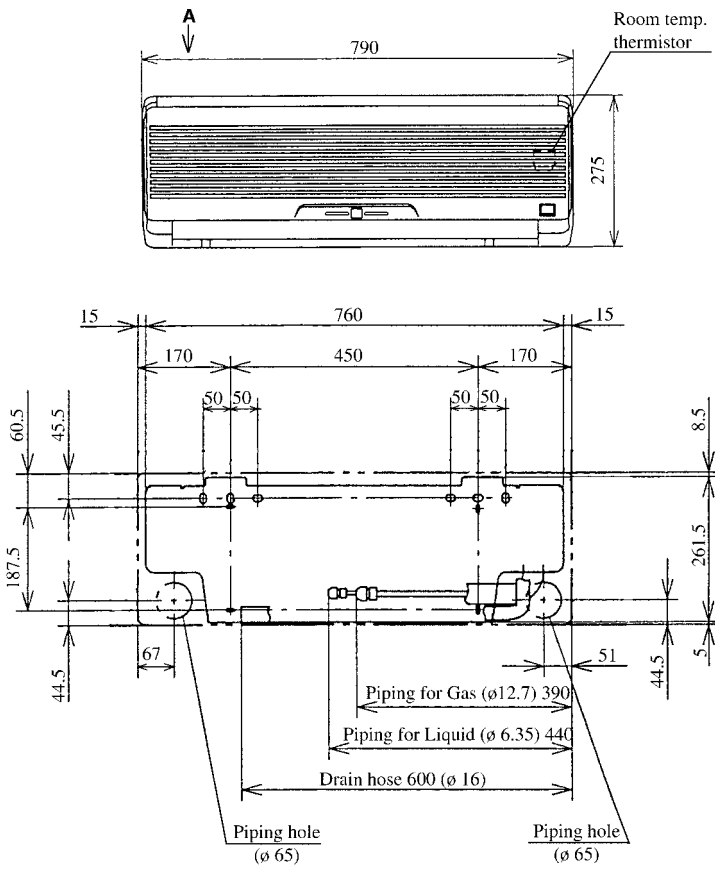

VIEW A

(2) Outdoor unit

Model SRC25GZ-L1

Unit: mm

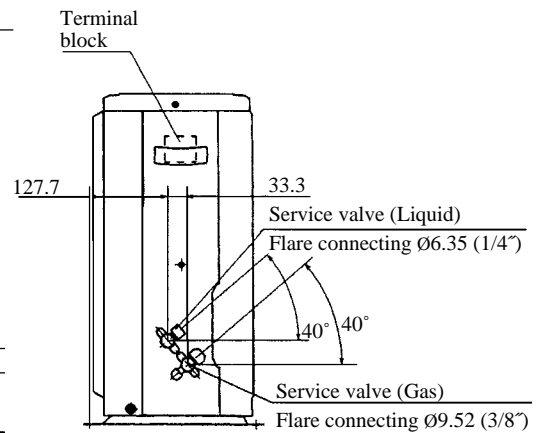
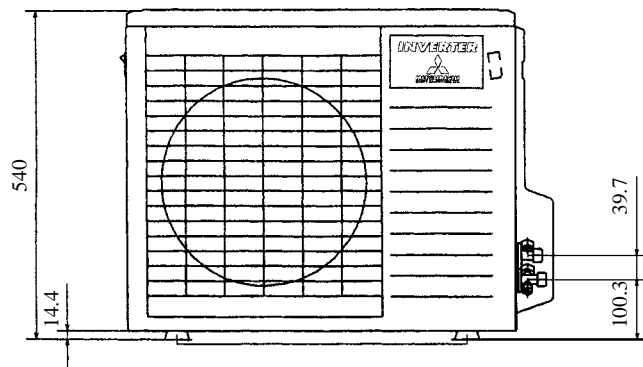
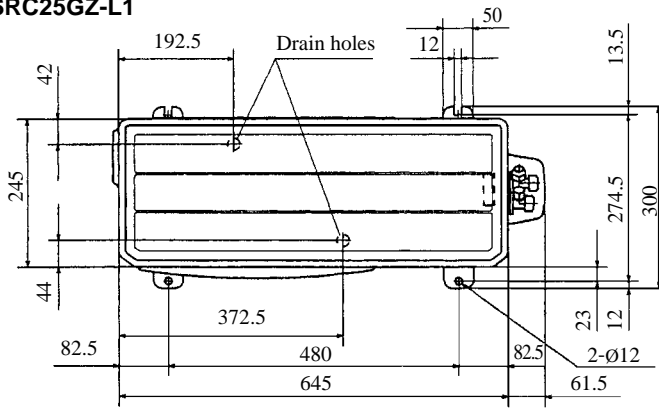

Model SRC35GZ-L1

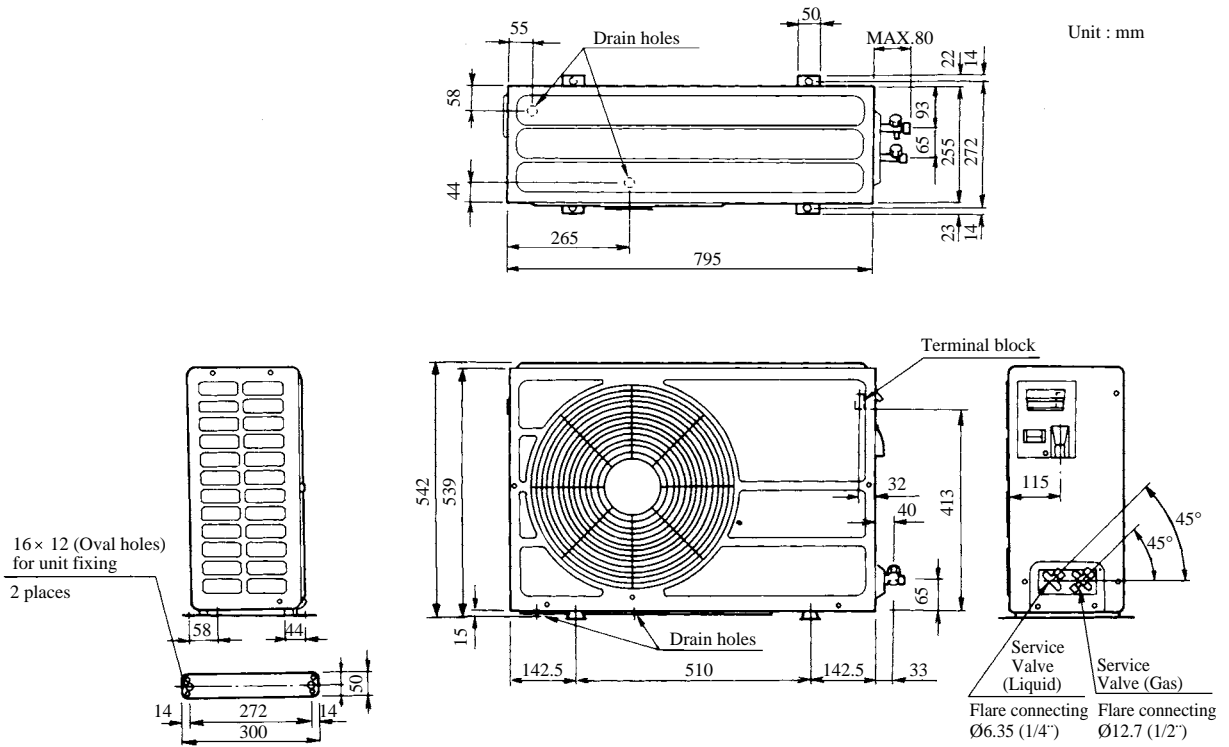

Model SRC502Z-L

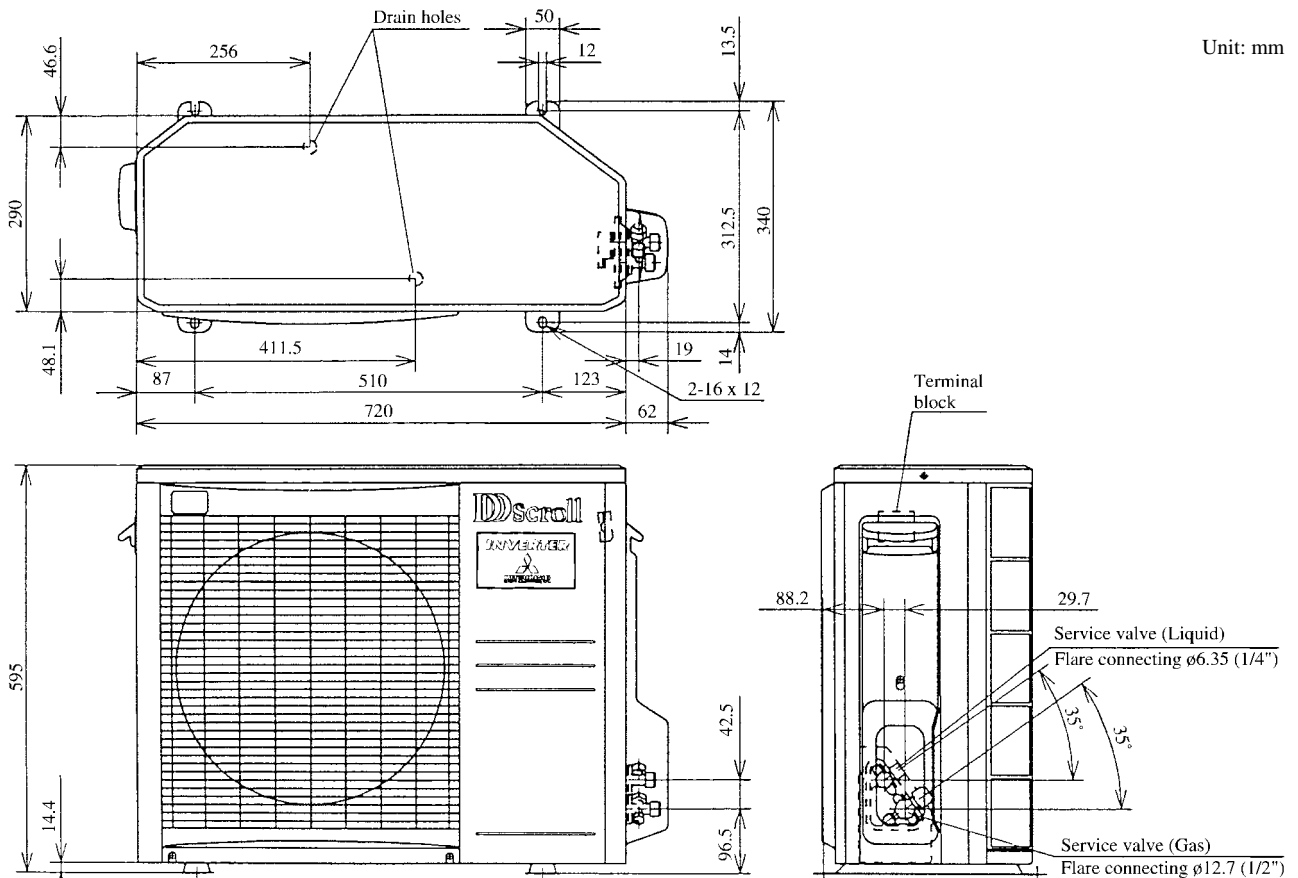

1.2.4 Piping system

Model SRK25GZ-L1

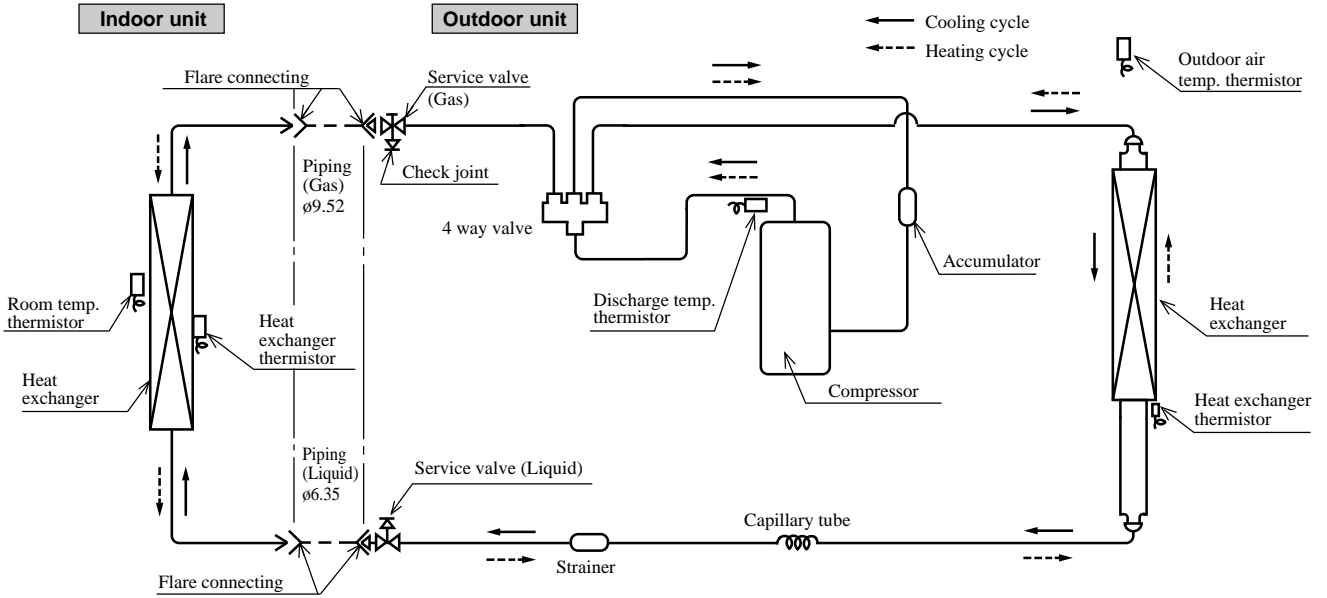

Model SRK35GZ-L1

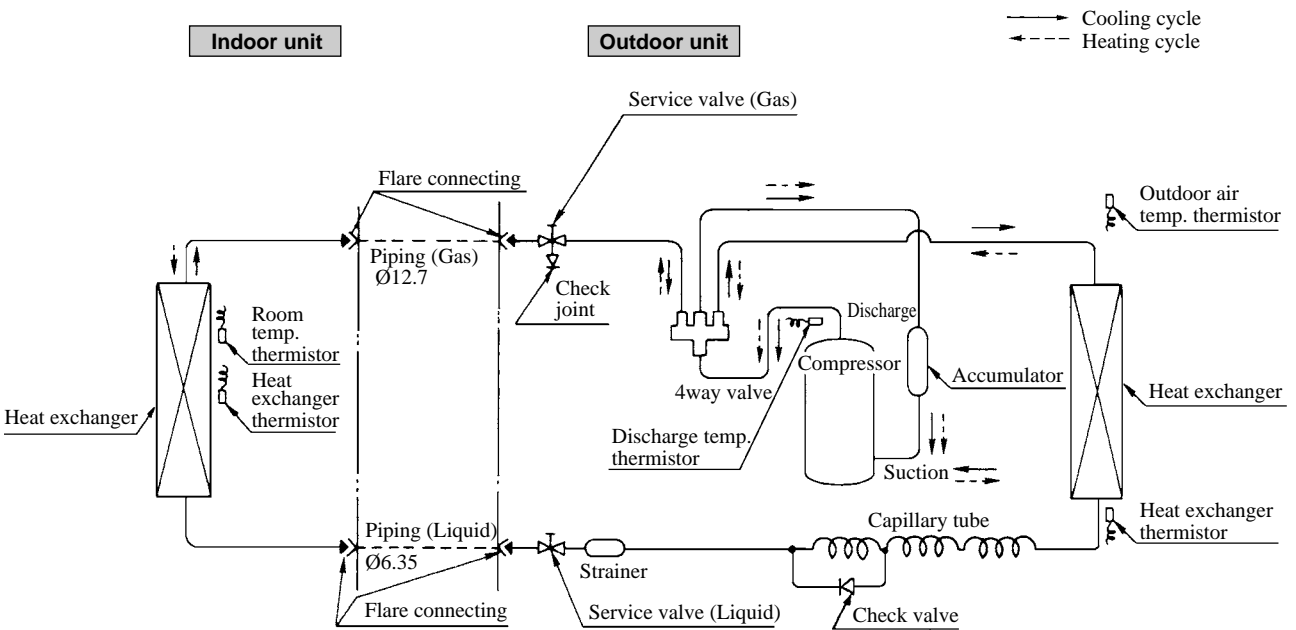

Model SRK502Z-L

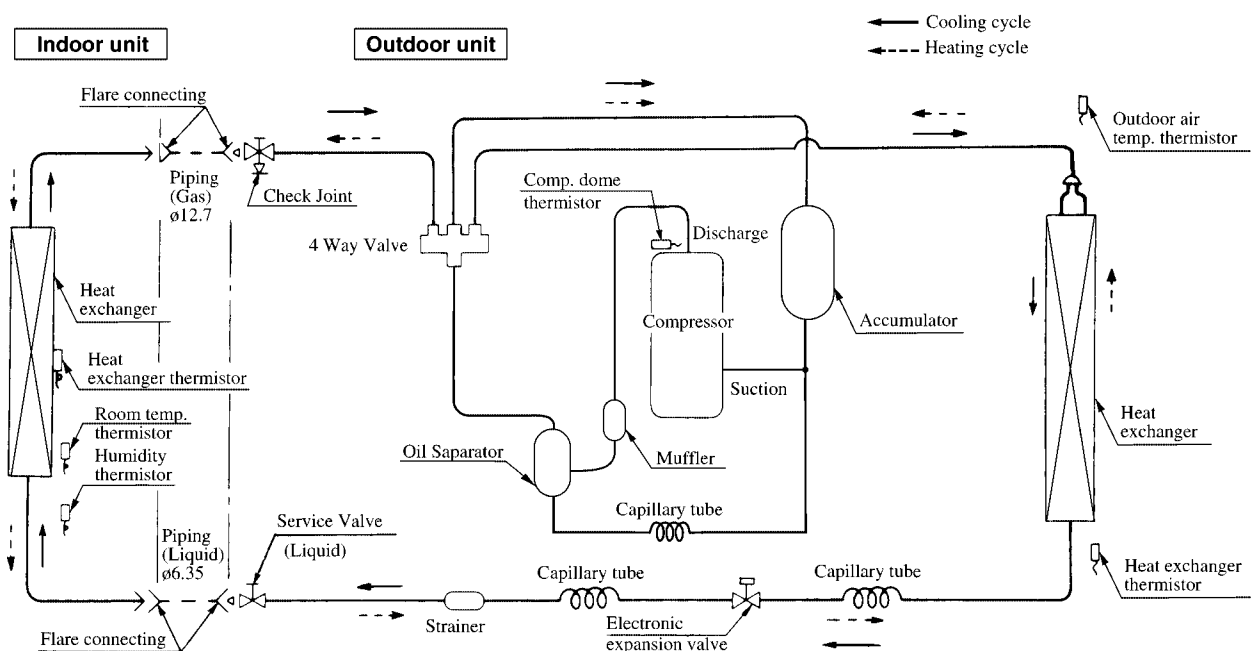

1.3 ELECTRICAL DATA

1.3.1 Electrical wiring

Meaning of marks

Symbol	Parts name	Symbol	Parts name	Symbol	Parts name
CF ₁	Capacitor for FMI	RE	Reactor	Tr	Transformer
CM	Compressor motor	SM	Flap motor	ZNR	Varistor
F _{1,2}	Fuse	Th ₁	Room temp. thermistor	20S	4 way valve (coil)
FMI	Fan motor (Indoor)	Th ₂	Heat exchanger thermistor (Indoor unit)	52C	Magnetic contactor
FMO	Fan motor (Outdoor)	Th ₃	Humidity thermistor	DS	Diode stack
NF	Noise filter	Th ₅	Heat exchanger thermistor (Outdoor unit)	C	Capacitor
RL	Inspection lamp	Th ₆	Outdoor air temp. thermistor	52X ₁₋₂	Auxiliary relay
NK	Noise killer	Th ₇	Discharge pipe temp. thermistor	EEV	Electronic expansion valve

Model **SRK25GZ-L1**

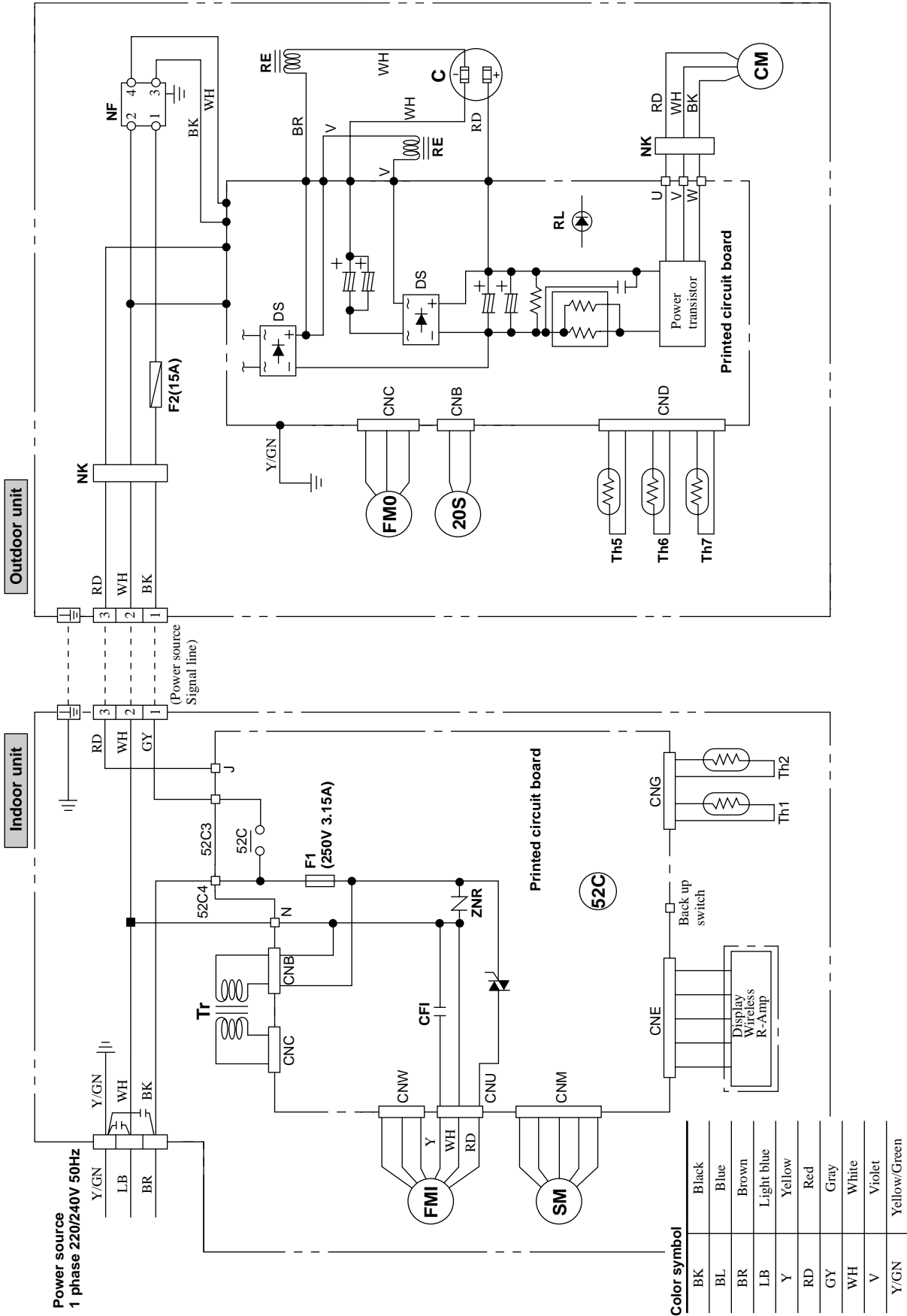

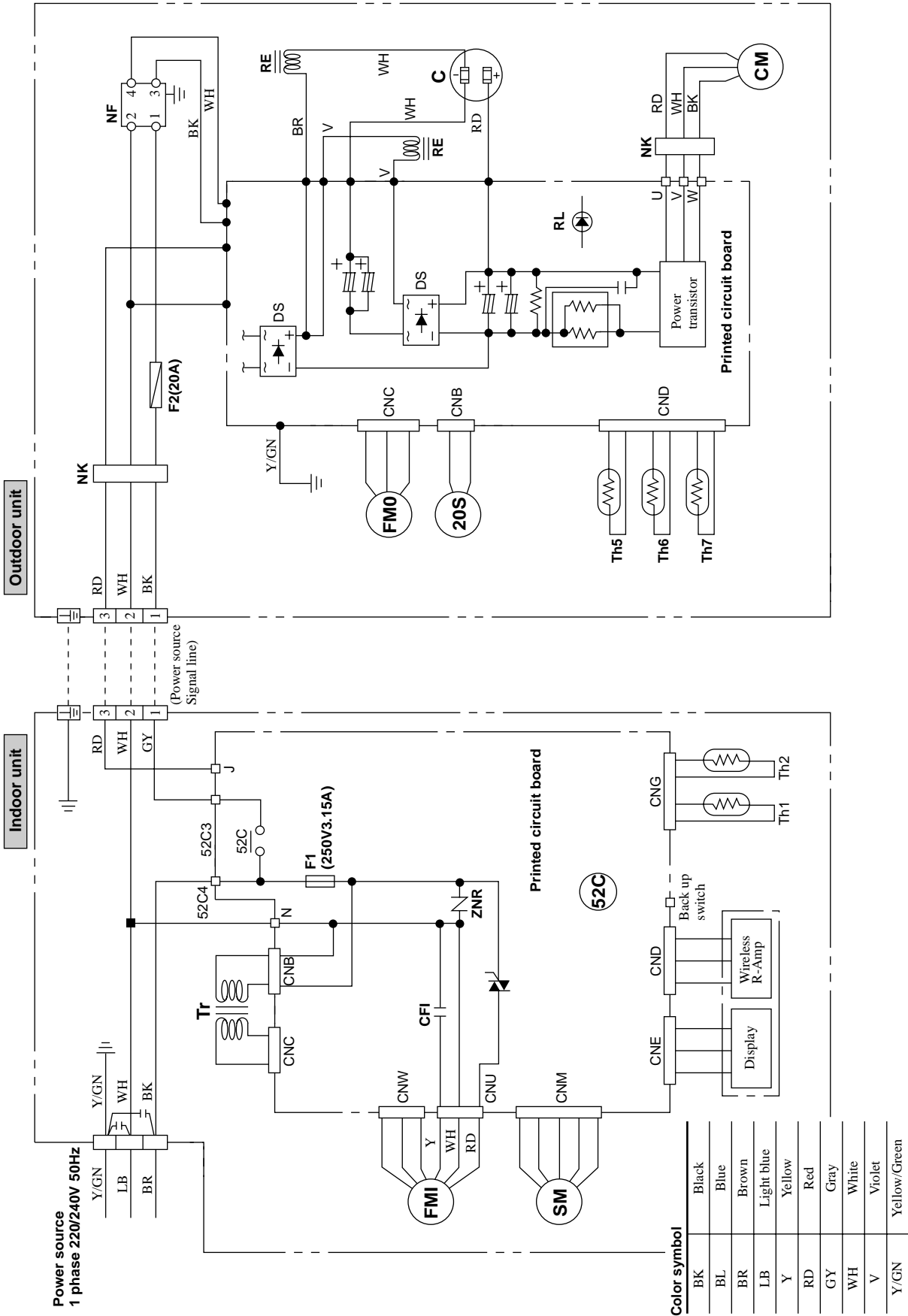

Model SRK502Z-L

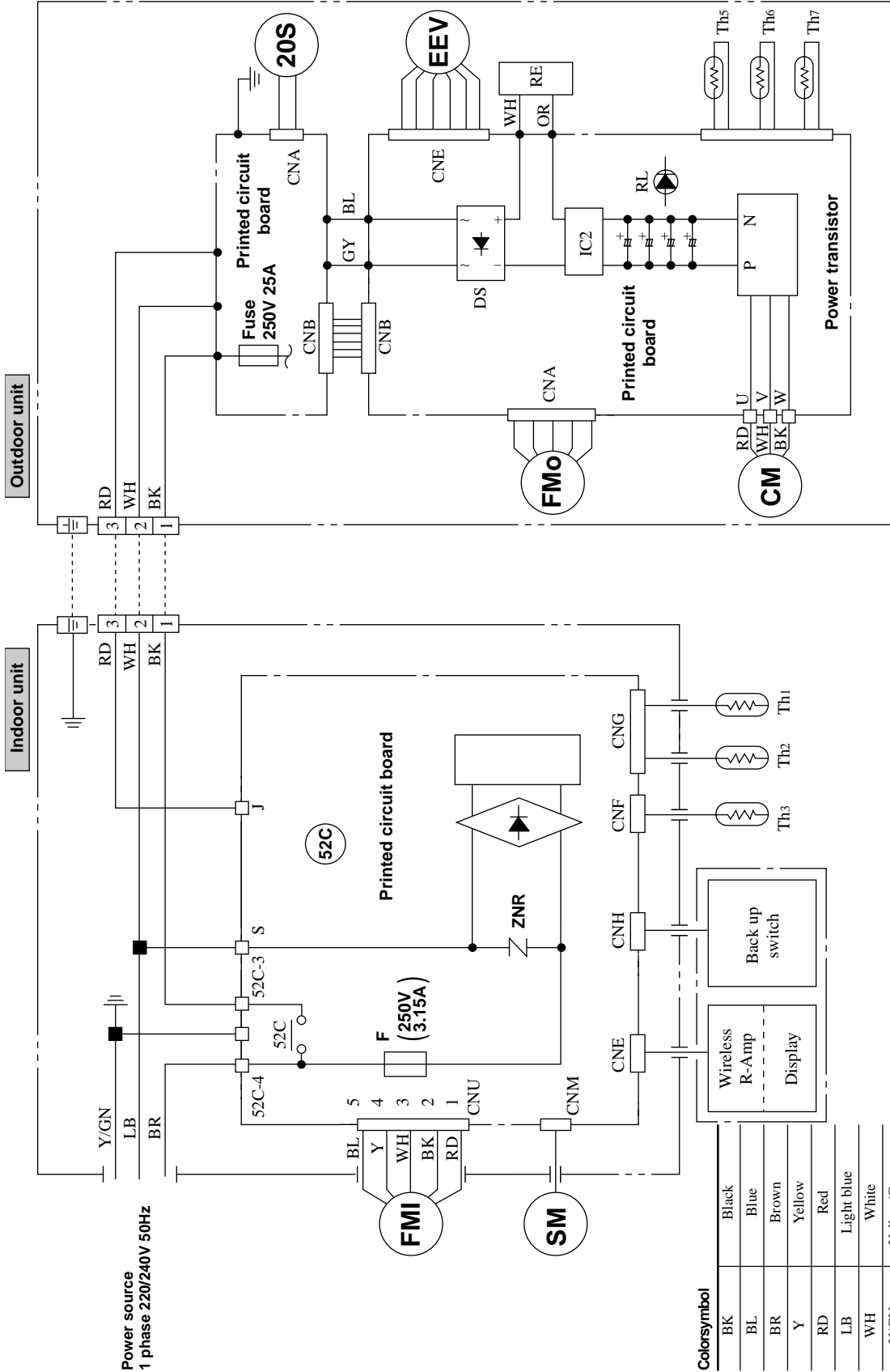

1.4 OUTLINE OF OPERATION CONTROL BY MICROCOMPUTER

(1) Remote control switch

Remote control switch

Models All models

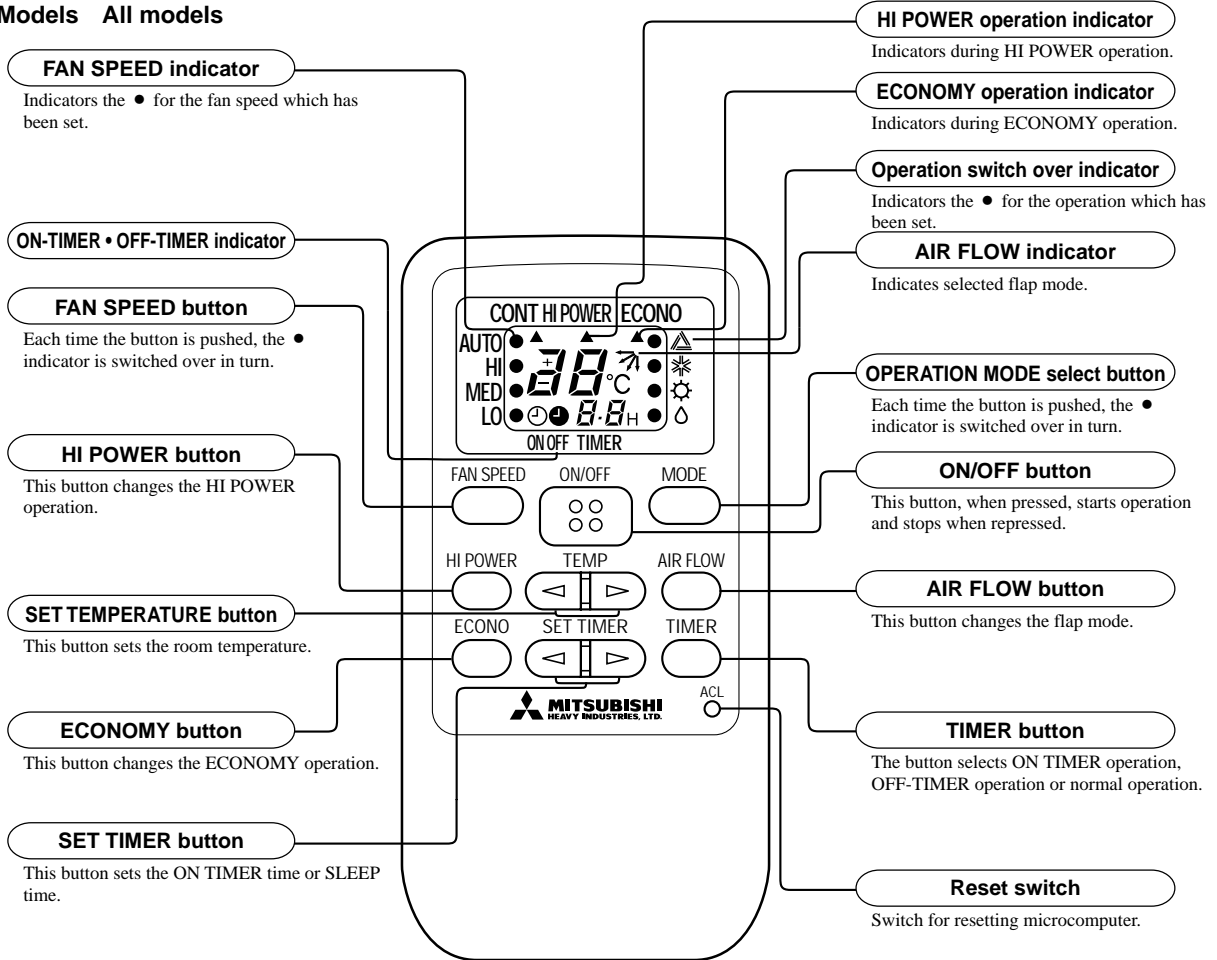

• Above figure shows all indications for the purpose of explanation, but practically only the pertinent parts are indicated.

Indoor unit indicator

Model SRK25GZ-L1

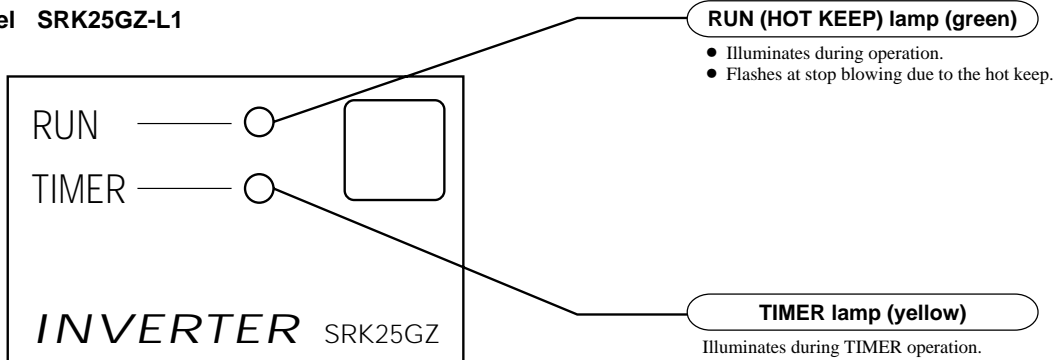

Model SRK35GZ-L1

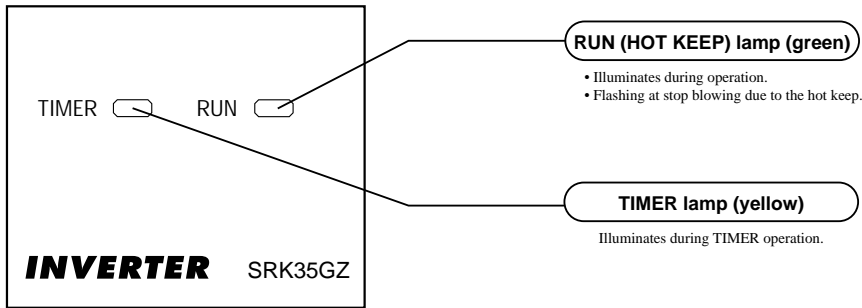

Model SRK502Z-L

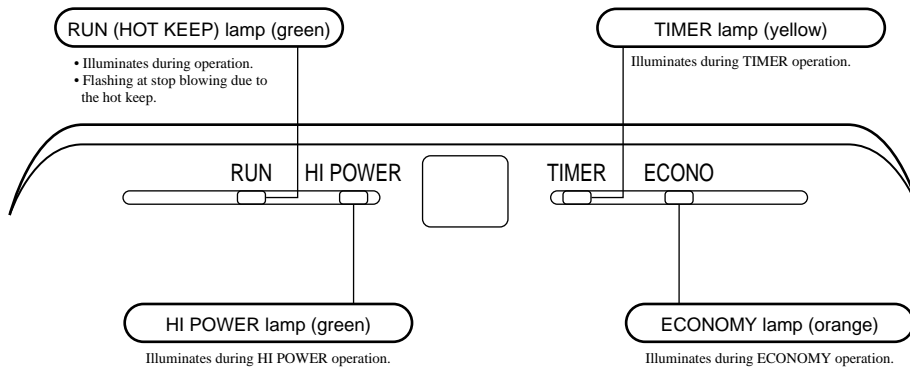

(2) Back-up switch

When the remote controller become weak, or if the remote controller is lost or malfunctioning, this switch may be used to turn the unit on and off.

(a) Operation

Push the switch once to place the unit in the automatic mode. Push it once more to turn the unit off.

(b) Detail of operation

Operation starts in the same way as the previous operation.

Model SRK25GZ-L1

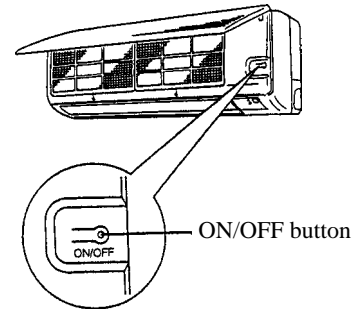

Model SRK35GZ-L1

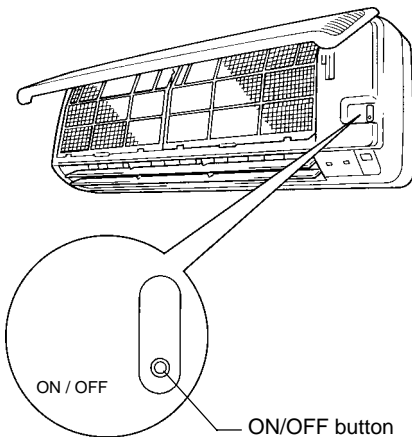

Model SRK502Z-L

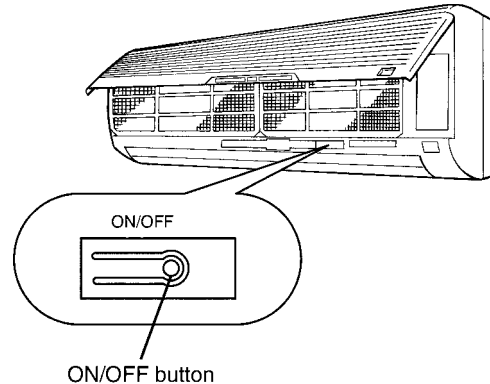

(3) Flap control

Control the flap by AIRFLOW button on the wireless remote control.

(a) Natural flow (AUTO)

The flap will be automatically set to the angle of air flow best to operation.

(i) Starting time of operation

Models SRK25GZ-L1, 35GZ-L1

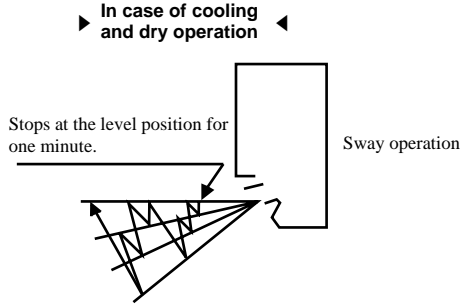

- The flap operation as shown above will be repeated.

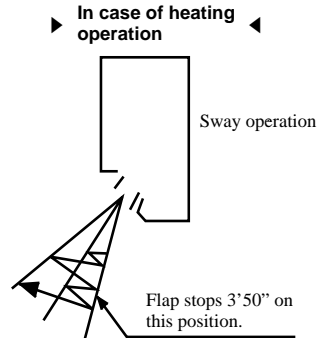

- When the room temperature controller (thermostat) is activated, horizontal blowing is applied to prevent cool wind from blowing out.

Model SRK502Z-L

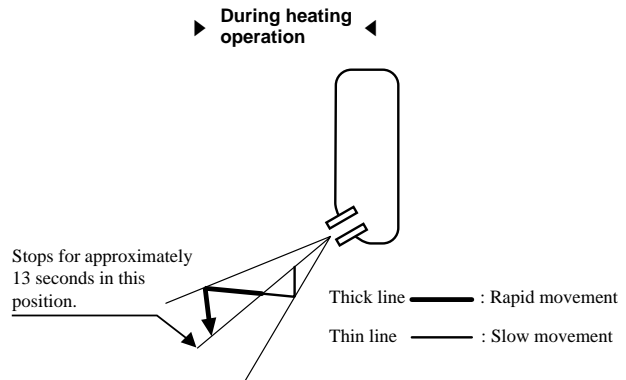
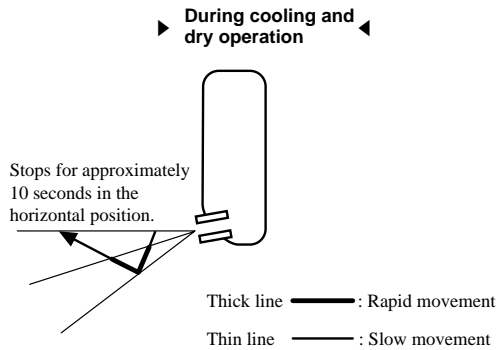

(ii) When not operating

The flap returns to the position of air flow directly below, when operation has stopped.

(b) Memory flap (Excepted SRK 25 model)

While the flap is operating if the AIRFLOW button is pushed once, it stops swinging at an angle.

As this angle is memorized in the microcomputer, the flap will be automatically set to the angle when next operation is started.

- Recommendable stopping angle of the flap

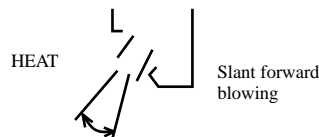
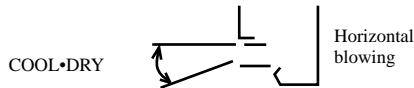

(c) Swing flap

Flap moves in upward and downward directions continuously.

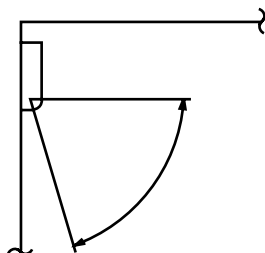

(4) Comfort timer setting

If the timer is set at ON when the operation select switch is set at the cooling or heating, or the cooling or heating in auto mode operation is selected, the comfort timer starts and determines the starting time of next operation based on the initial value of 15 minutes and the relationship between the room temperature at the setting time (temperature of room temperature sensor) and the setting temperature. (Max. 60 minutes)

Operation mode	Operation start time correction value (Min.)		
At cooling	3 < Room temp. - Setting temp.	1 < Room temp. - Setting temp. ≤ 3	Room temp. - Setting temp. ≤ 1
	+5	No change	-5
At heating	3 < Setting temp. - Room temp.	2 < Setting temp. - Room temp. ≤ 3	Setting temp. - Room temp. ≤ 2
	+5	No change	-5

- Notes (1) At 5 minutes before the timer ON time, operation starts regardless of the temperature of the room temperature sensor (Th1).
 (2) This function does not actuate when the operation select switch is set at the dehumidifying as well as the dehumidifying in the auto mode. However, the operation of item (1) above is performed during the dehumidifying in the auto mode.
 (3) During the pleasant reservation operation, both the operation lamp and timer lamp illuminate and the timer lamp goes off after expiration of the timer, ON setting time.

(Example) Heating

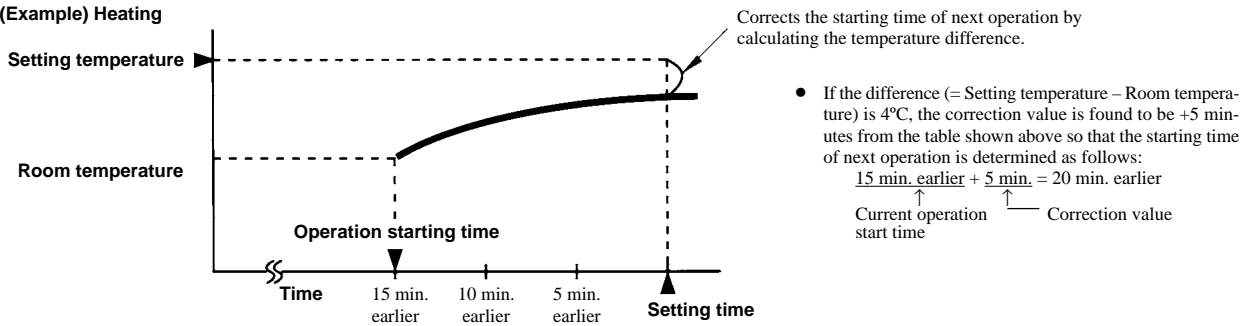

(5) Outline of heating operation

(a) Air flow selection

- (i) Frequency of inverter changes within the range of selected air flow.

Model		SRK25GZ-L1	SRK35GZ-L1	SRK502Z-L
Auto	Frequency	34~110Hz	34~110Hz	14~150rps
	Air flow	Depends on frequency.	Depends on frequency.	Depends on frequency.
HI	Frequency	34~110Hz	34~110Hz	14~150rps
	Air flow	5/6th speed	5~7th speed	6~8th speed
MED	Frequency	34~80Hz	34~94Hz	14~110rps
	Air flow	5th speed fixed	5th speed fixed	4~7th speed
LO	Frequency	34~50Hz	34~58Hz	14~50rps
	Air flow	3rd/4th speed	3rd speed fixed	2~5th speed

- (ii) When the defrosting, protection device, etc. is actuated, operation is performed in the corresponding mode.
 (iii) Outdoor unit blower operates in accordance with the frequency.

(b) Details of control at each operation mode (pattern)

(i) Fuzzy operation

Deviation between the room temperature setting correction temperature and the suction air temperature is calculated in accordance with the fuzzy rule, and used for control of the air capacity and the inverter frequency.

(ii) Heating thermostat operation

- Operating conditions

If the frequency obtained with the fuzzy calculation drops below -24 Hz (rps) during the heating fuzzy operation, the operation changes to the heating thermostat operation.

- Detail of operation

Inverter frequency	0Hz (rps) [Comp. stopped]
Indoor fan	Hot keep normal mode → 1st speed
Outdoor fan	Stop
Flap	Horizontal

(iii) Continuous mode operation (Temperature setting button on remote controller: Continuous)

Item	Model	SRK25GZ-L1				SRK35GZ-L1				SRK502Z-L			
		AUTO	HI	MED	LO	AUTO	HI	MED	LO	AUTO	HI	MED	LO
Inverter frequency		104Hz		98Hz	50Hz	98Hz		94Hz	58Hz	144rps		110rps	50rps
Indoor fan		6th speed		5th speed	4th speed	7th speed		5th speed	3rd speed	8th speed		7th speed	5th speed
Outdoor fan		ON				ON				5th speed		4th speed	2nd speed

Notes (1) In the continuous mode, the continuous heating operation is performed without adjustment of room temperature.

(2) Protective functions will be operated with priority even during the continuous mode operation.

(iv) Hot keep operation

If the hot keep operation is selected during the heating operation, the indoor blower is controlled based on the temperature of the indoor unit heat exchanger (detected with Th2, indoor unit heat exchanger sensor) to prevent blowing of cool wind.

◆ SRK25, 35GZ-L1

● Normal mode (Normal heating operation, operation after HI POWER completion)

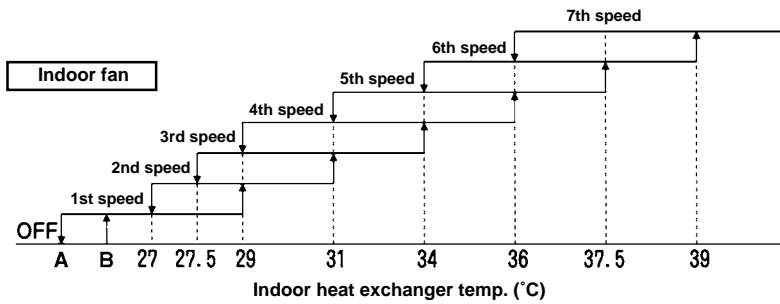

● Values of A, B

	A	B
At 0 Hz command	22	25
Other than 0 Hz command	17	19

Note (1) Refer to the table shown above right for the values A and B.

● Hot keep M mode [During HI POWER operation (for 15 min.)]

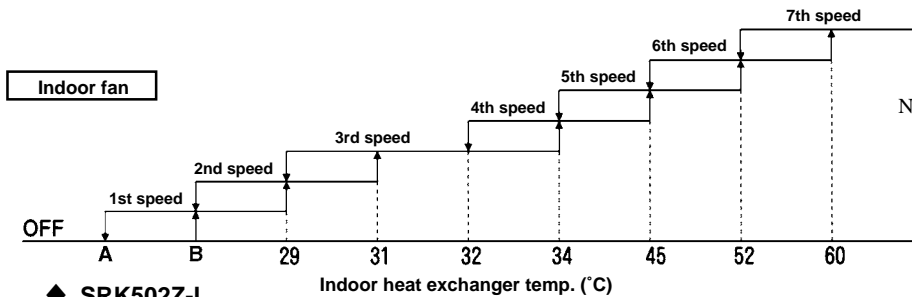

Note (1) Refer to the table shown above right for the values A and B.

◆ SRK502Z-L

● Normal mode (Normal heating operation, operation after HI POWER completion)

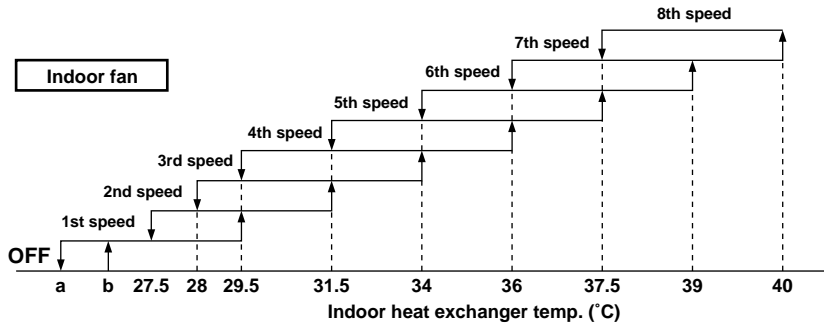

● Values of A, B

	A	B
At 0 Hz command	22	25
Other than 0 Hz command	17	19

Note (1) Refer to the table shown above right for the values A and B.

● Hot keep M mode [During HI POWER operation (for 15 min.)]

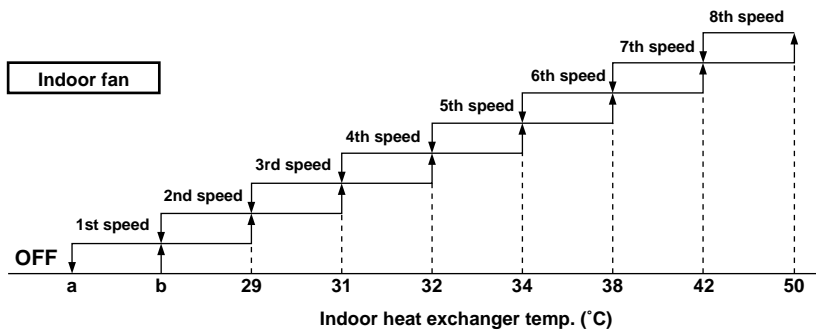

Note (1) Refer to the table shown above right for the values A and B.

(v) Defrosting operation

◆ **Models SRK25GZ-L1, 35GZ-L1**

1) Starting conditions (Defrosting operation can be started only when all of the following conditions are met.)

● **Model SRK25GZ-L1**

- ① After start of heating operation → When it elapsed 40 minutes. (Accumulated operation time)
- ② After end of defrosting operation → When it elapsed 40 minutes. (Accumulated compressor operation time)
- ③ Outdoor unit heat exchanger thermistor (Th5) temperature → When the temperature has been below -3°C for 3 minutes continuously.
- ④ When there is a big temperature difference between the outdoor unit heat exchanger thermistor (Th5) and the outdoor air temperature thermistor (Th6).
- ⑤ When the compressor is operating.

Moreover, the defrosting operation starts when the frequency command released from the indoor unit controller has counted 0 Hz for more than 10 times and when all conditions of ①, ② and ③ above (however, temperature of Th5 at -3°C or under) are met.

● **Model SRK35GZ-L1**

- ① After start of heating operation → When it elapsed 40 minutes. (Accumulated operation time)
- ② After end of defrosting operation → When it elapsed 40 minutes. (Accumulated compressor operation time)
- ③ Outdoor unit heat exchanger thermistor (Th5) temperature → When the temperature has been below -5°C for 3 minutes continuously.
- ④ Outdoor air temperature thermistor (Th6) - Outdoor unit heat exchanger thermistor (Th5) temperature $\geq 0.44 \times$ Outdoor air temperature thermistor temperature + 9°C or higher
- ⑤ When the compressor is operating.

Moreover, the defrosting operation starts when the frequency command released from the indoor unit controller has counted 0 Hz for more than 10 times and when all conditions of ①, ② and ③ above (however, temperature of Th5 at -3°C or under) are met.

2) Operation of functional components during defrosting operation

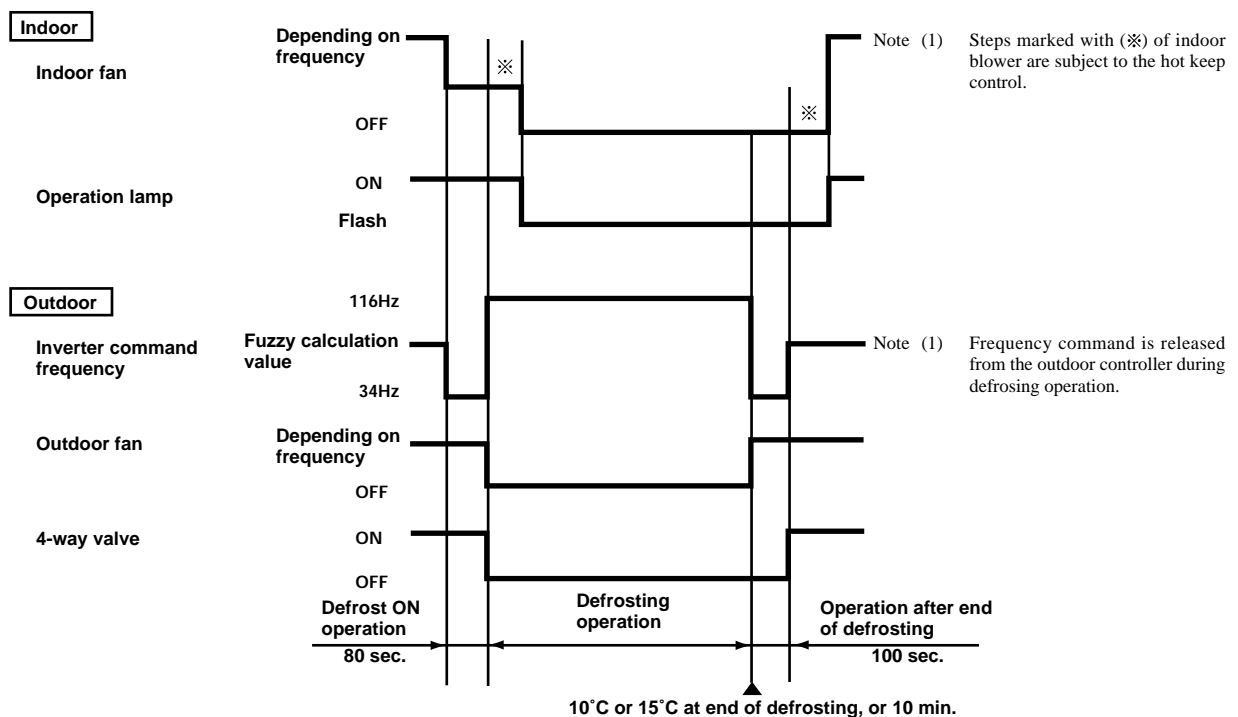

3) Ending conditions (Operation returns to the heating cycle when either one of the following is met.)

- ① Outdoor heat exchanger thermistor (Th5) temperature: 10°C or 15°C or higher
- ② Continued operation time of defrosting → For more than 10 min.

◆ **Model SRK502Z-L**

1) Starting conditions (Defrosting operation can be started only when all of the following conditions are met.)

- ① After start of heating operation → When it elapsed 60 minutes. (Accumulated operation time)
- ② After end of defrosting operation → When it elapsed 60 minutes. (Accumulated compressor operation time)
- ③ Outdoor unit heat exchanger thermistor (Th5) temperature → When the temperature has been below -2°C for 3 minutes continuously.
- ④ When outdoor air temperature thermistor (Th6) – outdoor heat exchanger liquid piping thermistor temperature (Th5) $\geq 0.44 \times$ outdoor air temperature thermistor (Th6) + A °C or more.
A value: $Th6 \geq -2 \text{ °C} \cdot 4$ $Th6 \leq -2 \text{ °C} \cdot 6$
- ⑤ During continuous compressor operation

In addition, when the speed command from the indoor controller of the indoor unit during heating operation has counted 0 rps 10 times or more and all conditions of ①, ② and ③ above are satisfied (note that when the temperature for Th5 is 62 rps or more: -2 °C or less, less than 62: -1 °C), defrost operation is started.

2) Operation of functional components during defrosting operation

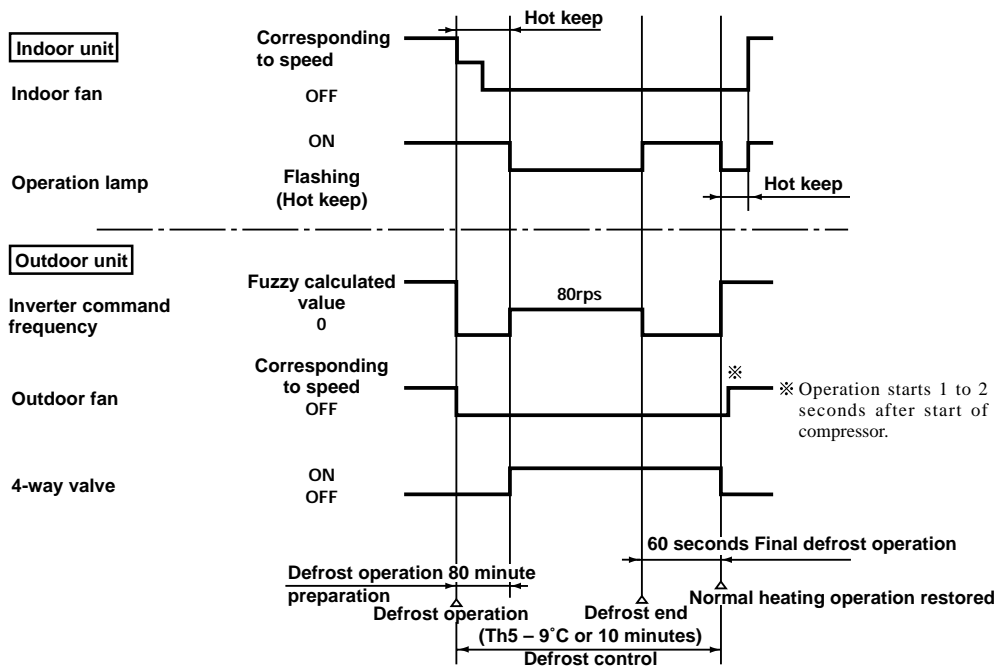

3) Ending conditions (Operation returns to the heating cycle when either one of the following is met.)

- ① Outdoor heat exchanger thermistor (Th5) temperature: 9°C higher.
- ② Continued operation time of defrosting → For more than 10 min.

(vi) Hot standby (Excepted SRK502 model)

1) Conditions (Hot standby occurs when all of the following conditions are met.)

- ① When it lapsed 2 hours continuously after the command frequency turned to 0 Hz during heating operation.
- ② When the temperature detected with the external temperature sensor is below -2°C.

2) Detail

Low voltage is applied to the compressor from the inverter so as to preheat the compressor in which refrigerant melted in the refrigeration oil is vaporized, circulated smoothly at the start of heating operation and, as a result, the startup of heating operation is speeded up.

3) Hot standby is reset when the external temperature turns to 0°C or when the unit has not been operated for more than 24 hours continuously.

(vii) Heating “HI POWER” operation (HI POWER button on remote controller: ON)

Operation is maintained for 15 minutes with a higher blow out air temperature.

● Detail of operation

Model	SRK25GZ-L1	SRK35GZ-L1	SRK502Z-L
Item			
Inverter command frequency	112Hz	110Hz	126rps
Indoor fan	Hot keep M mode		
Outdoor fan	Depends on frequency		

- Notes (1) When the hot keep fan speed and the fan speed corresponding to the frequency command are not matched, the fan is operated with the fan speed whichever lower.
- (2) Room temperature is not adjusted during the HI POWER operation.
- (3) Protective functions will actuate with priority even during the HI POWER operation.

(6) Outline of cooling operation

(a) Air capacity selection

(i) Frequency of inverter changes within the range of selected air flow.

Model		SRK25GZ-L1	SRK35GZ-L1	SRK502Z-L
Air flow selection	Frequency	34~92Hz	34~102Hz	18~118rps
	Air flow	Depends on frequency.		
HI	Frequency	34~92Hz	34~102Hz	18~118rps
	Air flow	5/6th speed	5/6th speed	5~7th speed
MED	Frequency	34~68Hz	34~86Hz	18~92rps
	Air flow	4th speed fixed	4/5th speed	4/5th speed
LO	Frequency	34~44Hz	34~44Hz	18~44rps
	Air flow	3/4th speed	3rd speed	3/4th speed

(ii) When any protective function actuates, the operation is performed in the mode corresponding to the function.

(iii) Outdoor blower is operated in accordance with the frequency.

(b) Detail of control in each mode (Pattern)

(i) Fuzzy operation

During the fuzzy operation, the air flow and the inverter frequency are controlled by calculating the difference between the room temperature setting correction temperature and the suction air temperature.

(ii) Cooling thermostat operation

1) Operating conditions

During the cooling fuzzy operation or when the frequency obtained by the fuzzy calculation is less than -24 Hz.

2) Detail of operation

Inverter frequency	0Hz [Comp. stopped]
Indoor fan	Corresponds to fan speed switch.
Outdoor fan	Stop

(iii) Continuous mode operation (Temperature setting button on remote controller: Continuous)

Model	SRK25GZ-L1				SRK35GZ-L1				SRK502Z-L			
	AUTO	HI	MED	LO	AUTO	HI	MED	LO	AUTO	HI	MED	LO
Inverter frequency	82Hz		68Hz	44Hz	86Hz		52Hz		140rps		90rps	46rps
Indoor fan	5th speed		4th speed		5th speed		3rd speed		8th speed		6th speed	4th speed
Outdoor fan	ON				ON				5th speed		3rd speed	2nd speed

Notes (1) In the continuous mode, the unit is operated with the continuous cooling operation without adjustment of room temperature.

(2) Protective functions will actuate with priority even during the continuous mode operation.

(iv) Cooling “HI POWER” operation (HI POWER button on remote controller: ON)

The unit is operated continuously for 15 minutes regardless of the setting temperature.

1) Detail of operation: Following cycle is repeated 3 times.

Model	SRK25GZ-L1		SRK35GZ-L1		SRK502Z-L	
	1 cycle		1 cycle		1 cycle	
Item	2 min.	3 min.	2 min.	3 min.	2 min.	3 min.
Inverter frequency	92Hz		102Hz		108rps	
Indoor fan	5th speed	6th speed	6th speed	7th speed	6th speed	7th speed
Outdoor fan	ON		ON		Me	

Notes (1) Protective functions will actuate with priority even during the “HI POWER” operation.

(2) Room temperature is not adjusted during the “HI POWER” operation

(3) “HI POWER” operation is prohibited during the operation controlled with the pleasant reservation timer.

(7) Outline of dehumidifying operation

(a) After operating the indoor blower for 20 seconds from immediately after the start of operation, the indoor temperature is checked and, based on the result of check, the cooling oriented dehumidifying or heating oriented dehumidifying is selected.

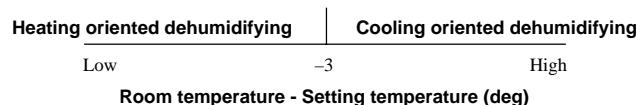

Cooling or heating oriented dehumidifying is selected again one hour after the first selection of the cooling or heating oriented dehumidifying.

(b) Outline of control

(i) Cooling oriented dehumidifying

◆ SRK25, 35GZ-L1

Room temperature is checked at 3-minute intervals after selecting the cooling or heating oriented dehumidifying in order to determine the operation range.

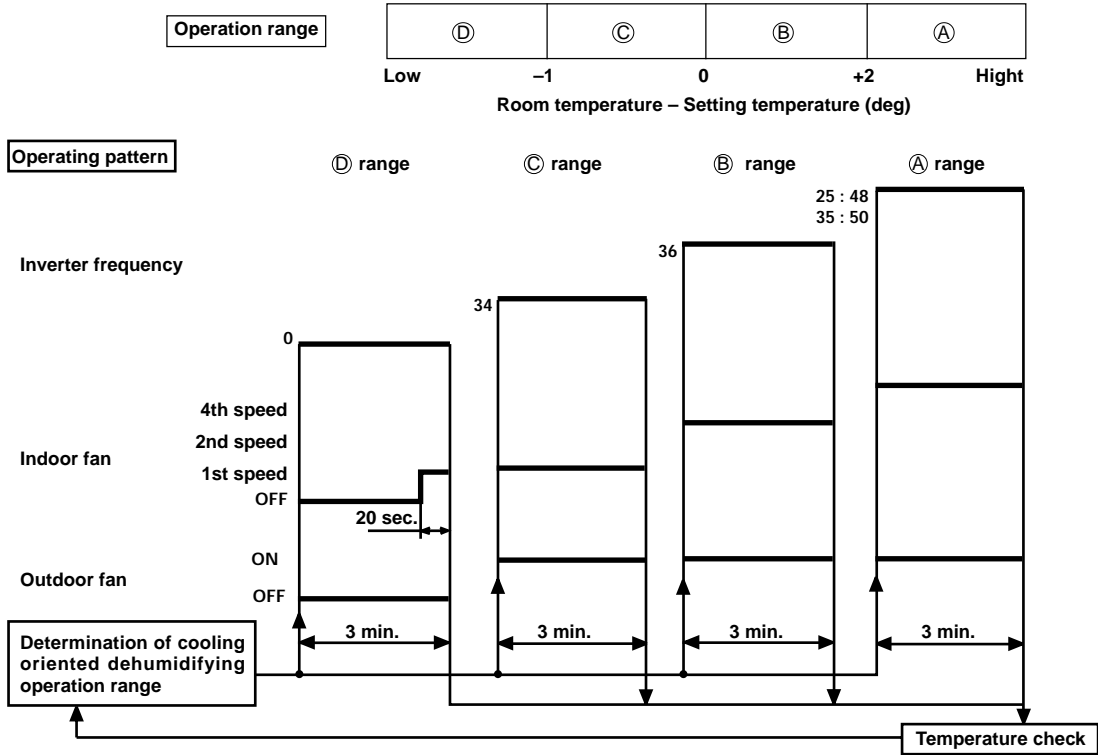

◆ SRK502Z-L

Temperature and humidity are checked at 3-minute intervals after selecting the cooling or heating oriented dehumidifying in order to determine the operation range.

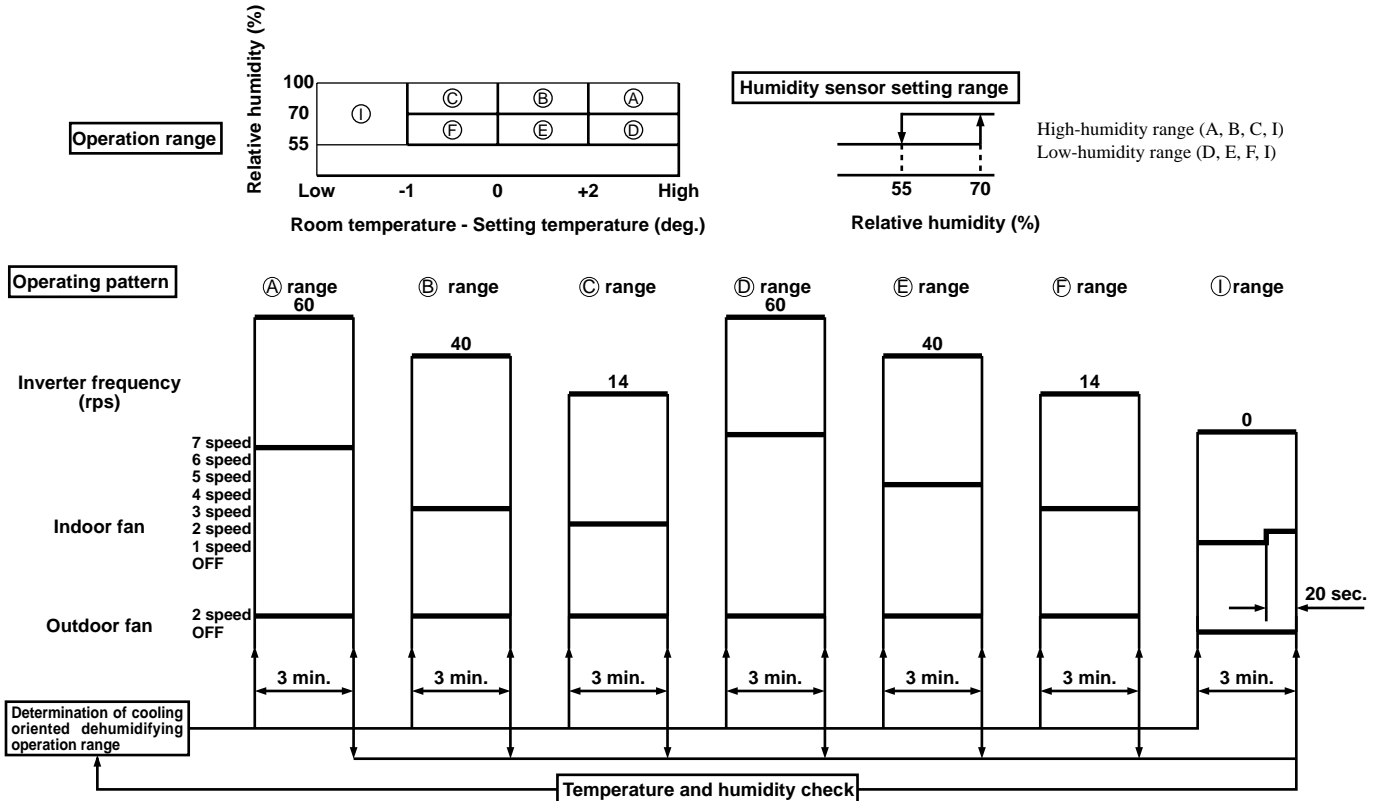

(ii) Heating oriented dehumidifying

After interrupting the compressor operation for 3 minutes (by the 3-minute timer) following the determination of heating oriented dehumidifying, the unit enters in the heating operation. If the room temperature exceeds the setting temperature by 2°C or more, the unit checks the room temperature at 3-minute intervals and, depending on the result, determines the range of heating oriented dehumidifying operation.

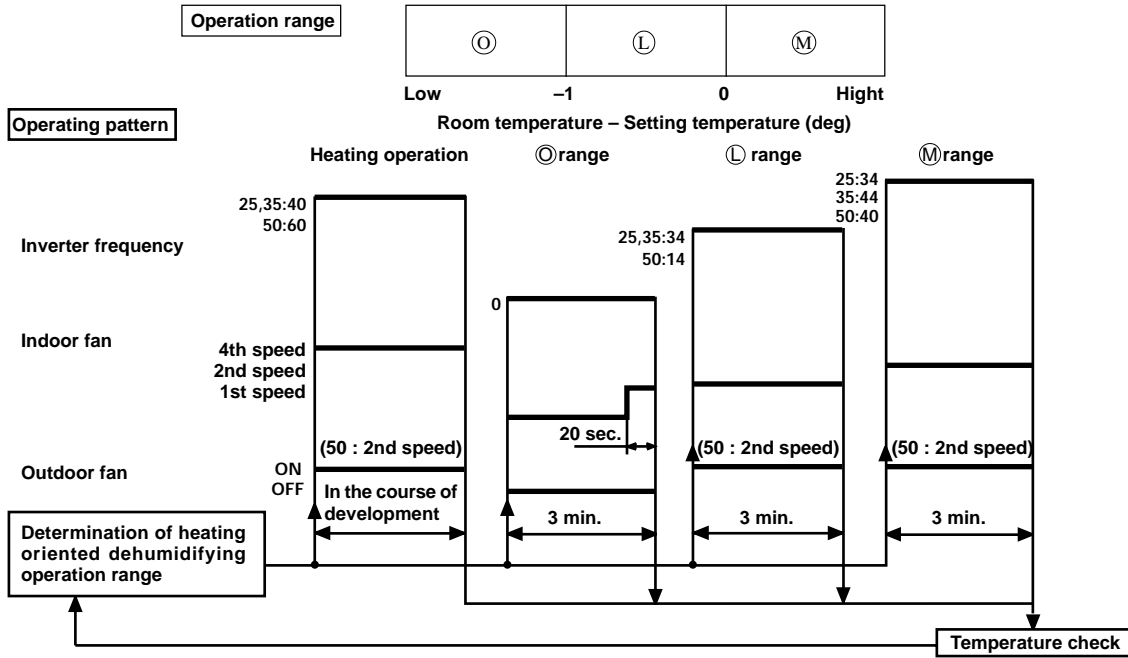

(iii) Continuous dehumidifying operation (Temperature setting button on remote controller: Continuous)

Item \ Model	SRK25GZ-L1	SRK35GZ-L1	SRK50ZZ-L
Inverter frequency	36Hz	44Hz	40rps
Indoor fan	2nd speed	2nd speed	4th speed
Outdoor fan	ON	ON	2nd speed

Notes (1) Protective function will actuate with priority even during the continuous mode.

(2) If the “Room temperature setting” is changed to 18~30°C during the continuous dehumidifying operation, the unit enters in the cooling oriented dehumidifying operation.

(8) Outline of automatic operation

(a) Determination of operation mode

The unit checks the room temperature and the outdoor air temperature after operating the indoor and outdoor blowers for 30 seconds, determines the operation mode and the room temperature setting correction value, and then enters in the automatic operation.

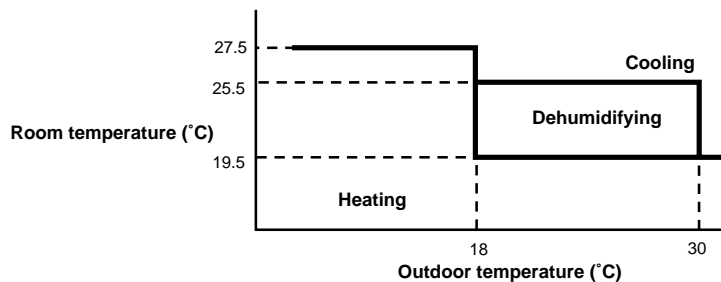

- (b) The unit checks the temperature every hour after the start of operation and, if the result of check is not same as the previous operation mode, changes the operation mode.
- (c) When the unit is started again within one hour after the stop of automatic operation or when the automatic operation is selected during heating, cooling or dehumidifying operation, the unit is operated in the previous operation mode.
- (d) Setting temperature can be adjusted within the following range. There is the relationship as shown below between the signals of the wireless remote controller and the setting temperature.

		Signals of wireless remote controller (Display)													
		-6	-5	-4	-3	-2	-1	±0	+1	+2	+3	+4	+5	+6	
Setting temperature	Cooling	20	21	22	23	24	25	26	27	28	29	30	31	32	
	Dehumidifying	19	20	21	22	23	24	25	26	27	28	29	30	31	
	Heating	19	20	21	22	23	24	25	26	27	28	29	30	31	

(9) Economical operation (ECONO button on remote controller: ON)

Pressing the economy button initiates a soft operation with the power suppressed in order to avoid an excessive cooling or heating. The unit operates 1.5°C higher than the setting temperature for the LO air flow during cooling or 2.5°C lower than that during heating.

(10) Protective control function

(a) Frost prevention for indoor heat exchanger (During cooling or dehumidifying)

(i) Operating conditions

- (i) Indoor heat exchanger temperature (detected with Th2) is lower than 2.5°C.
- (ii) 10 minutes elapsed after the start of operation.

(ii) Detail of anti-frost operation

Inverter command speed	0Hz
Indoor fan	2nd speed
Outdoor fan	OFF
4-way valve	Stop mode

(iii) Reset conditions: Indoor heat exchanger temperature (Th2) is higher than 8°C.

(b) Indoor fan motor protection

When the air conditioner is operating and the indoor fan motor is turned ON, if the indoor fan motor has operated at 300 rpm or under for more than 30 seconds, the unit enters first in the stop mode and then stops the entire system.

Timer lamp illuminates simultaneously and the operation lamp flashing 6 times at each 8-second.

(c) Continuous low Hz operation protection

When the command frequency from the indoor control has been suppressed at 18rps (40 Hz) or under (other than 0 rps(Hz)) for more than 15(45) minutes in order for the reverse feed of oil to the compressor, the compressor is operated forcibly at 30rps (60Hz) for 20(30) seconds (1 minutes). However, the speed of indoor fan is not changed.

Notes (1) If a command exceeding 30rps (60 Hz) is received during the forced operation at 30rps (60 Hz), the command governs the operation.

(2) Value in () indicates 25, 35 models.

(d) Current safe

(i) Purpose: Current is controlled not to exceed the upper limit of the setting operation current.

(ii) Detail of operation: Input current to the converter is monitored with the current sensor assembled on the printed circuit board of the outdoor unit and, if the operation current value reaches the limiting current value, the inverter frequency is reduced.

If the mechanism is actuated when the frequency of outdoor unit is less than 25:28 Hz, 35:34 Hz, 50:30 rps, the compressor is stopped immediately. Simultaneously, a red LED on the printed circuit board provided on the outdoor unit controller flashing 3 times for 0.5 second at intervals of 8 seconds. Operation starts again after a delay time of 3 minutes but, if the mechanism is actuated again at less than 25:28 Hz, 35:34 Hz, 50:30 rps, the operation does not start on the third time.

(e) Current cut

(i) Purpose: Inverter is protected from overcurrent.

(ii) Detail of operation: Output current from the converter is monitored with a shunt resistor and, if the current exceeds the setting value, the compressor is stopped immediately. Simultaneously, a red LED on the printed circuit board provided on the outdoor unit controller flashing for 0.5 second at intervals of 8 seconds. Operation starts again after a delay time of 3 minutes but, if the current cut mechanism is actuated again before it reaches less than 25:28 Hz, 35:34 Hz, 50:20 rps, the operation does not start on the third time.

(f) Heating overload protective control

(i) Operating conditions: When the unit is operating with the outdoor unit frequency other than 0 Hz(rps) or when the outdoor temperature thermistor temperature rose beyond 17°C for 2 minutes continuously.

(ii) Detail of operation

- 1) Indoor fan speed is raised forcibly by 1 step.
- 2) Taking the upper limit of control frequency range at 25,35:60 Hz, 50:70 rps, if the output frequency obtained with the fuzzy calculation exceeds the upper limit, the upper limit value is maintained.

(iii) Reset conditions: When the outdoor thermistor temperature drops below 16°C.

(g) Cooling overload protective control

(i) Operating conditions: When the unit is operating with the outdoor unit frequency other than 0 Hz(rps) or when the outdoor temperature sensor temperature rose beyond 41°C for 2 minutes continuously.

(ii) Detail of operation

◆ **SRK25GZ-L1**

- 1) Indoor fan speed is raised forcibly by 1 step. However, the maximum speed is the 3rd speed.
- 2) 10A current safe operation
Taking the lower limit of control frequency at 34 Hz, if the output frequency obtained with the fuzzy calculation reaches this value, the operation changes to the thermostat operation.

◆ **SRK35GZ-L1**

- 1) 10A current safe operation

◆ **SRK50Z-L**

- 1) Outdoor fan speed is raised forcibly by 1 step.
- 2) With the controlled lower limit speed at 20 rps, there will be thermostat operation if the output speed by fuzzy calculation reaches this value.
- 3) The controlled upper limit speed control is 94 rps.

(iii) Reset conditions: When the external temperature thermistor temperature drops below 40°C.

(h) Freezing cycle system protective control

(i) Operating conditions: When both of following conditions have continued for more than 5 minutes later than 5 minutes after the start of operation.

- 1) Command frequency is higher than 60 Hz(rps)
- 2) During cooling, dehumidifying: Indoor heat exchanger temperature - Room temperature > - 4°C
During heating: Indoor heat exchanger temperature - Room temperature < 6°C

(ii) Detail of operation: Changes immediately the command frequency to 0 Hz and stops the operation on the entire system.

◆ **SRK25, 35GZ-L1**

Changes immediately the command frequency to 0 Hz and stops the operation on the entire system.

◆ **SRK50Z-L**

The command speed repeats 30 minutes at 30rps ↔ 2 minutes at 62 rps. It is cancelled if outside of 1) or 2) above.

(i) Compressor overheat protection

(i) Purpose: It is designed to prevent deterioration of oil, burn of motor oil and other trouble resulting from the compressor overheat.

(ii) Detail of operation

- 1) Frequencies are controlled with temperature detected by the thermistor mounted on the discharge pipe (Comp. dome).

(Example) Fuzzy

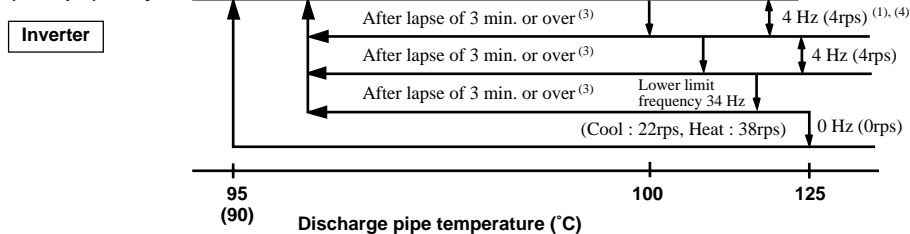

- Notes
- (1) When the discharge pipe temperature is in the range of 100 to 125°C, the frequency is reduced by 4 Hz (4rps).
 - (2) When the discharge pipe temperature is raised and continues operation for 20 seconds without charging, then the frequency is reduced again by 4 Hz (4rps).
 - (3) When the discharge pipe temperature is in the range of 95 to 100°C, and if the inverter frequency is being maintained and the operation has continued for more than 3 minutes at the same frequency, it returns to the normal operation.
 - (4) Value in () indicates 50 model.

- 2) If the temperature of 125°C is detected by the thermistor on the discharge pipe (Comp. dome), then the compressor will stop immediately.
Simultaneously, the red LED on the printed circuit board of outdoor unit controller flashing 5 times for 0.5 second at interval of 8 seconds. When the discharge temperature drops and the time delay of 3 minutes is over, the unit starts again within 1 hour but there is no start at the third time.

(J) Serial signal transmission error protection

(i) Purpose: Prevents malfunction resulting from error on the indoor ↔ outdoor signals.

(ii) Detail of operation: When the indoor unit controller ↔ outdoor unit controller signals cannot be received, the compressor is stopped immediately. Simultaneously, the red LED on the printed circuit board of outdoor unit controller flickers 6 time for 0.5 second at intervals of 8 seconds. Once the operation stops, it does not start any more.

(Timer lamp on the indoor unit flashing at the same time.)

(k) High pressure control

(i) Purpose: Prevents abnormally high pressure operation during heating.

(ii) Detector: Indoor unit heat exchanger thermistor (Th2)

(iii) Detail of operation: (Example) Fuzzy

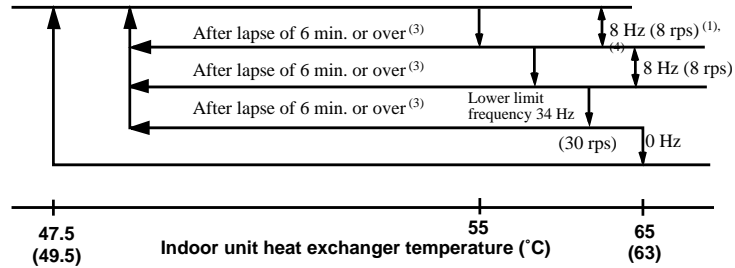

- Notes (1) When the indoor unit heat exchanger temperature is in the range of 55 - 65(63)°C, the frequency is reduced by 8 Hz (8 rps) at each 20 seconds.
 (2) When the indoor unit heat exchanger temperature is in the range of 47.5(49.5) - 55°C, if the inverter command frequency is been maintained and the operation has continued for more than 6 minutes at the same frequency, it returns to the normal heating operation.
 (3) Indoor blower retains the fan tap when it enters in the high pressure control. Outdoor blower is operated in accordance with the frequency.
 (4) value in () indicates 50 model.

(l) Stop mode

(i) Operating conditions: When the operation mode is changed, when the dehumidifying operation is changed from the heating oriented mode to the cooling oriented mode or vice versa, or when the inverter frequency turns to 0 Hz.

[When 0 Hz is commanded from the indoor unit controller, when an outdoor protective function is actuated]

(ii) Detail of operation

◆ SRK25GZ-L1, 35GZ-L1

Function	Operation	When stopped by indoor unit controller		When stopped or reset by outdoor unit protective function	
		Heating, heating oriented dehumidifying	Cooling, cooling oriented dehumidifying	Heating, heating oriented dehumidifying	Cooling, cooling oriented dehumidifying
Inverter frequency	(Command frequency) 0	3 min. ⁽¹⁾	3 min. ⁽¹⁾	2 min. 55 sec.	2 min. 55 sec.
Indoor fan	(Frequency dependent) OFF			Hot keep	
Indoor power relay	ON OFF				
Outdoor fan	ON OFF	10 sec.	10 sec.	10 sec.	10 sec.
4-way valve	ON OFF	2 min.	2 min.	2 min.	2 min.
		Stop Full stop (0 Hz command)	Stop Full stop (0 Hz command)	Stop Restart (0 Hz command)	Stop Restart (0 Hz command)

Note (1) When the start delay of compressor of indoor unit controller is actuated and the operation is reset, it takes 2 minutes and 55 seconds.

◆ **SRK502Z-L**

Function	Operation	When stopped by indoor unit controller		When stopped or reset by outdoor unit protective function	
		Heating, heating oriented dehumidifying	Cooling, cooling oriented dehumidifying	Heating, heating oriented dehumidifying	Cooling, cooling oriented dehumidifying
Inverter frequency	(Command frequency) 0				
Indoor fan	(Frequency dependent) OFF				
Indoor power relay	ON OFF				
Outdoor fan	ON OFF				
4-way valve	ON OFF				
		Stop Full stop (0 rps command)	Stop Full stop (0 rps command)	Stop Restart (0 rps command)	Stop Restart (0 rps command)

Note (1) When the start delay of compressor of indoor unit controller is actuated and the operation is reset, it takes 2 minutes and 55 seconds.

1.5 APPLICATION DATA



SAFETY PRECAUTIONS

- Please read these “Safety Precautions” first then accurately execute the installation work.
- Though the precautionary points indicated herein are divided under two headings, **⚠WARNING** and **⚠CAUTION**, those points which are related to the strong possibility of an installation done in error resulting in death or serious injury are listed in the **⚠WARNING** section. However, there is also a possibility of serious consequences in relationship to the points listed in the **⚠CAUTION** section as well. In either case, important safety related information is indicated, so by all means, properly observe all that is mentioned.
- After completing the installation, along with confirming that no abnormalities were seen from the operation tests, please explain operating methods as well as maintenance methods to the user (customer) of this equipment, based on the owner’s manual. Moreover, ask the customer to keep this sheet together with the owner’s manual.

WARNING

- This system should be applied to places as households, residences and the like. Application to inferior environment such as engineering shop could cause equipment malfunction.
- Please entrust installation to either the company which sold you the equipment or to a professional contractor. Defects from improper installations can be the cause of water leakage, electric shocks and fires.
- Execute the installation accurately, based on following the installation manual. Again, improper installations can result in water leakage, electric shocks and fires.
- For installation, confirm that the installation site can sufficiently support heavy weight. When strength is insufficient, injury can result from a falling of the unit.
- For electrical work, please see that a licensed electrician executes the work while following the safety standards related to electrical equipment, and local regulations as well as the installation instructions, and that only exclusive use circuits are used.
Insufficient power source circuit capacity and defective installment execution can be the cause of electric shocks and fires.
- Accurately connect wiring using the proper cable, and insure that the external force of the cable is not conducted to the terminal connection part, through properly securing it improper connection or securing can result in heat generation or fire.
- Take care that wiring does not rise upward, and accurately install the lid/service panel. It’s improper installation can also result heat generation or fire.
- When setting up or moving the location of the air conditioner, do not mix air etc. or anything other than the designated refrigerant (R22) within the refrigeration cycle.
Rupture and injury caused by abnormal high pressure can result from such mixing.
- Always use accessory parts and authorized parts for installation construction. Using parts not authorized by this company can result in water leakage, electric shock, fire and refrigerant leakage.
- Ventilate the work area when refrigerant leaks during the operation. 
Coming in contact with fire, refrigerant could generate toxic gas.
- Confirm after the foundation construction work that refrigerant does not leak.
If coming in contact with fire of a fan heater, a stove or movable cooking stove, etc., refrigerant leaking in the room could generate toxic gas.

CAUTION

- Execute proper grounding. Do not connect the ground wire to a gas pipe, water pipe, lightning rod or a telephone ground wire.
Improper placement of ground wires can result in electric shock. 
- The installation of an earth leakage breaker is necessary depending on the established location of the unit.
No installing an earth leakage breaker may result in electric shock.
- Do not install the unit where there is a concern about leakage of combustible gas.
The rare even of leaked gas collecting around the unit could result in an outbreak of fire. 
- For the drain pipe, follow the installation manual to insure that it allows proper drainage and thermally insulate it to prevent condensation. Inadequate plumbing can result in water leakage and water damage to interior items.

1.5.1 Selection of location for installation

(1) Indoor unit

- (a) Where there is no obstructions to the air flow and where the cooled air can be evenly distributed.
- (b) A solid place where the unit or the wall will not vibrate.
- (c) A place where there will be enough space for servicing. (Where space mentioned below can be secured)
- (d) Where wiring and the piping work will be easy to conduct.
- (e) The place where receiving part is not exposed to the direct rays of the sun or the strong rays of the street lighting.

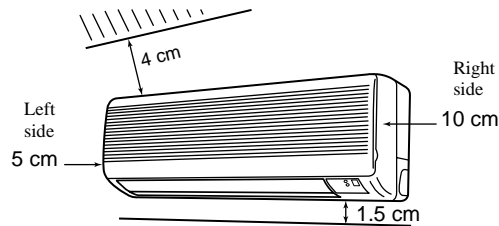

(2) Outdoor unit

- (a) A place where good air circulation can be obtained.
- (b) A place where the exhausted air will not be sucked in for the second time.
- (c) A place where the unit will not be affected by other heat sources. (When there are several units installed or another heat source)
- (d) Do not install the unit near the seaside, or where there is possibility of chlorine gas generation.
- (e) A place where discharged hot and cold air or unit's operating sound will not be a nuisance to the neighborhood.
- (f) A place where servicing space can be secured.

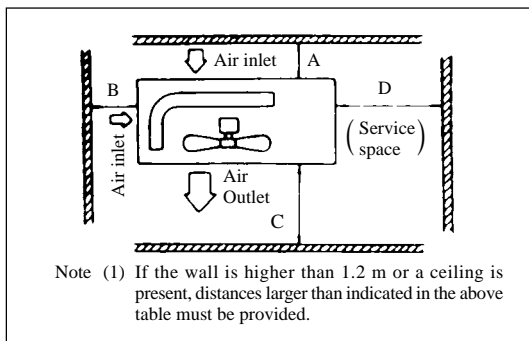

Unit : mm

Item	Mark			
	A	B	C	D
SRK25GZ-L1	100	100	300	250
SRK35GZ-L1	100	300	1000	2000
SRK502Z-L	100	100	300	250

- (g) A place where vibration will not be enlarged.
- (h) In heating operation, snow deposit on the heat-exchanger of outdoor unit must be prevented for keeping the normal performance capacity.
 - (i) Snow-hood on outdoor unit as in drawing, will reduce the frequency of defrost operation.
When installing the snow hood, take care so that the air outlet of the snow hood will not face directly into the most windy direction.
 - (ii) Design the base higher than possible snow deposit.

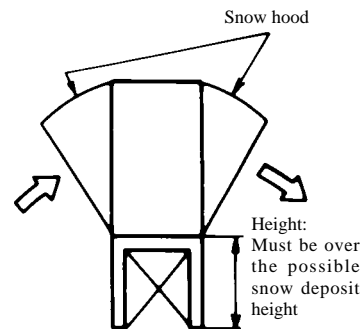

(3) Limitations for one way piping length and vertical height difference.

Item	Model	SRK25GZ-L1 SRK35GZ-L1	SRK502Z-L
	One way piping length (ℓ)		15 m
Vertical height difference (H)	Outdoor unit is lower	5 m	15 m
	Outdoor unit is higher	5 m	15 m

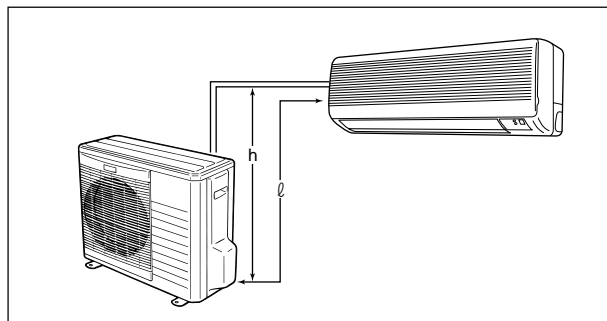

1.5.2 Installation of indoor unit

(1) Installation of installation board

(a) Fixing of installation board

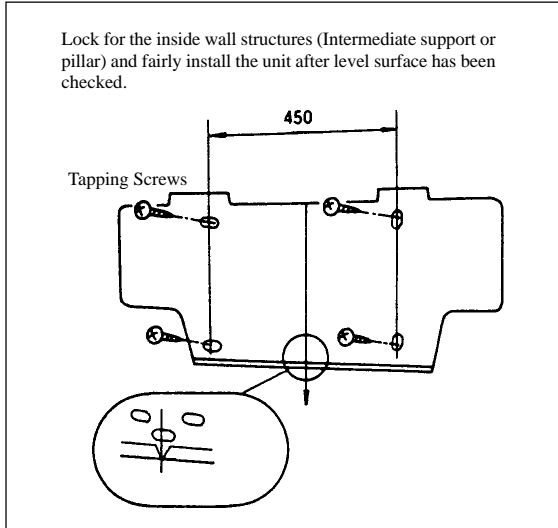

Adjustment of the installation board in the horizontal direction is to be conducted with four screws in a temporary tightened state.

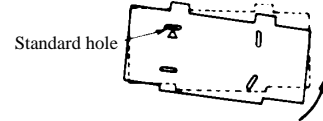

Adjust so that board will be level by turning the board with the standard hole as the center.

Fixing on concrete wall	
Use of nut anchor	Use of bolt anchor
<p>Bolt (M6 × 12) Mounting board</p>	<p>Nut (M6) Mounting board Max. 10</p>

(2) Drilling of holes and fixture sleeve (Option parts)

(a) Drill a hole with $\phi 65$ whole core drill

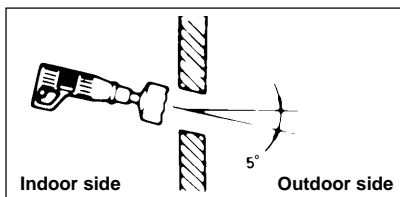

Note (1) Drill a hole with incline of 5 degree from indoor side to outdoor side.

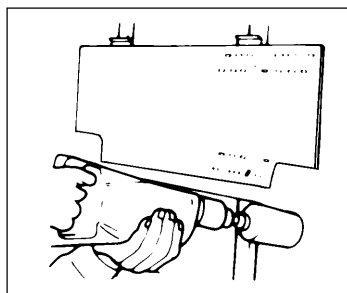

(b) Adjusting sleeve length

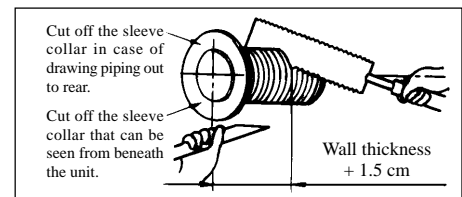

(c) Install the sleeve

(Inserting sleeve)

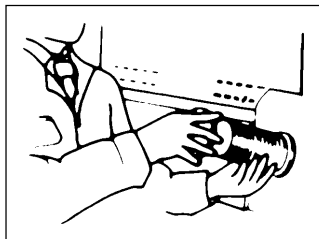

(*Sleeve + *Inclined + *Sealing plate)

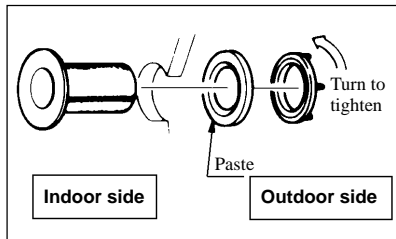

View of sleeve when installed

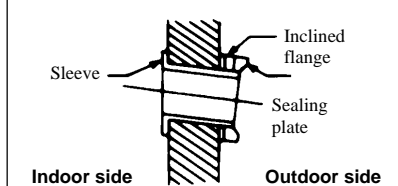

(3) Preparation of indoor unit

(a) Mounting of connecting wires

◆ SRK25, 35GZ-L1

- (i) Remove lid
- (ii) Remove cover, terminal block cover
- (iii) Insert connecting wire to terminal block securely.
 - ① Insert connecting wire up to the terminal block securely. If poor insertion of conductor may result in imperfect contact between the conductor and the terminal causing heat generation which may result in fire hazard.
 - ② Be careful not to confuse terminal numbers of connecting wire between indoor and outdoor unit.
 - ③ Use wiring clamp for connection wiring to avoid loosening of the wire.
- (iv) Install cover, terminal block cover.
- (v) Install lid.

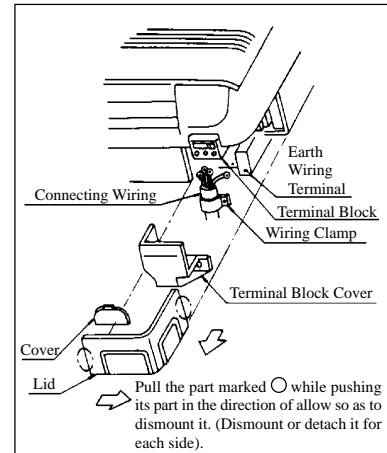

◆ SRK502Z-L

- (i) Open the suction grille, then remove the lid.
- (ii) Remove the wiring clamp.
- (iii) Pass the connecting wire to terminal block from behind of indoor unit.
- (iv) Connect the connecting wire securely to the terminal block.
 - ① Connect the connection wire securely to the terminal block. If the wire is not affixed completely, contact will be poor, and it is dangerous as the terminal block may heat up and catch fire.
 - ② Take care not to confuse the terminal numbers for indoor and outdoor connections.
 - ③ Affix the connection wire using the wiring clamp.
- (v) Fix the connecting wire by wiring clamp.
- (vi) Attach the lid.
- (vii) Close the suction grille.

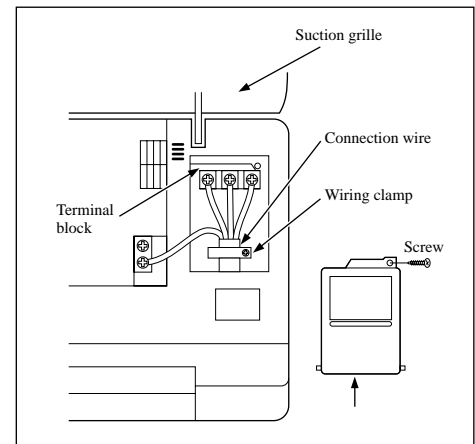

①	Brown	For power supply, indoor outdoor
②	Blue	Connecting wiring
③	Black	Indoor/outdoor signal wire (Low voltage)
⊕	Yellow/Green	Earth wiring terminal

Note (1) Connection wiring should not exceed 15 m. If this length is exceeded, communication errors are likely to occur between the outdoor and indoor units, which could stop the air conditioner.

(b) Protective taping (Protect the cable with tape at the section where the cable passes through the hole opened on the wall.)

(c) Forming of pipe (Holding down the pipe at the root, change the pipe direction, extend it and adjust according to the circumstance.)

[When the pipe is extended to left and taken out from the rear center]

(Drain pipe relocation procedure)

1. Remove the drain pipe.	2. Remove the drain cap.	3. Insert the drain cap.	4. Connect the drain pipe.

- Loosen the spring clamp to remove.
- Remove by hand or use cutting pliers, etc.
- Securely insert the drain cap removed in the step 2.
Note: If it is inserted insufficiently, water leakage
- Loosen the spring clamp and securely insert the drain pipe.
Note: If it is inserted insufficiently, water leakage could result.

- When arranging the pipe through a hole opened at the center, open the knockout hole using nippers, etc.

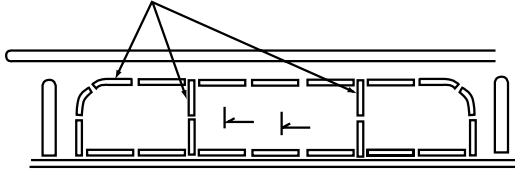

Note (1) It is designed to collect moisture accumulated on the rear face in the drain pan. Be sure not to accommodate the power cable, etc. above the chute.

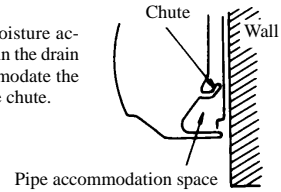

(4) Installation on indoor unit

(a) Install the indoor unit on the mounting plate.

Hook the upper part of the indoor unit on the stoppers disposed at the upper part of the mounting plate and lightly push the lower part of the indoor unit so that the unit is fixed in position.

- When removing the indoor unit
 - Disconnect the lid at right and left.
 - Pull down the stoppers (right and left) provided at the bottom of the indoor unit base. (See the detail view shown at right.)

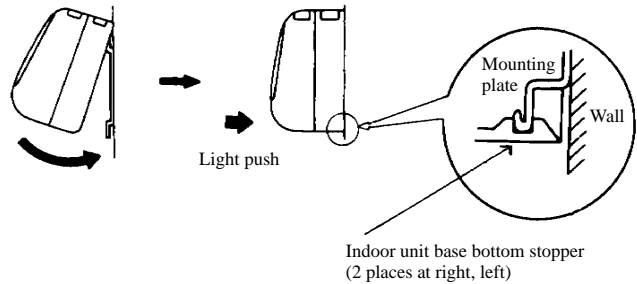

(b) Be sure not to leave any trap on the drain pipe.

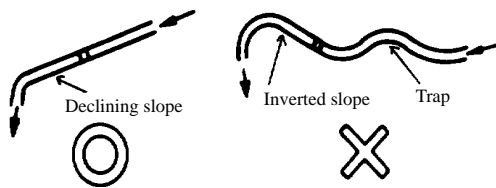

1.5.3 Installation of outdoor unit

(1) Installation of outdoor unit

- Make sure that sufficient space for installation and service is secured.
- Fix the leg sections of the unit on a firm base which will not play. Attach cushion pads, etc. between the unit and the mounting fixtures not to transmit vibration to the building.
- Attach a drain elbow, etc. under the drain port of the bottom plate to guide drain water. (Drain elbow should not be used where days when temperature drops below 0°C continue for several days. Draining may be disturbed by frozen water.)
- When installing the unit at a higher place or where it could be toppled with strong winds, secure the unit firmly with foundation bolts, wire, etc.

(2) Connection of indoor and outdoor connecting wiring

- Connect the wiring according to the number of the indoor terminal block. (Mis-wiring may cause the burning damage, and make sure to connect correctly.)

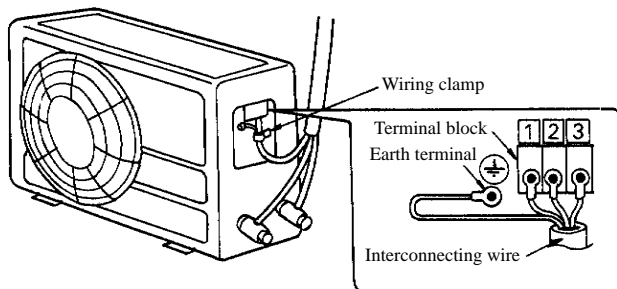

①	Brown	For power supply, indoor outdoor
②	Blue	Connecting wiring
③	Black	Indoor/outdoor signal wire (Low voltage)
⊕	Yellow/Green	Earth Wiring Terminal

Notes (1) To prevent the mis-operation by noise, when the connecting wire too long for indoor and outdoor. Please hide the fixed wire in the pipe or use vinyl tape to set. Do not put wire into the unit.

(2) Please let the anchored personal to decide by indoor wiring code whether connect the leakage breaker or not.

1.5.4 Refrigerant piping

(1) Preparation

Keep the openings of the pipes covered with tapes etc. to prevent dust, sand, etc. from entering them.

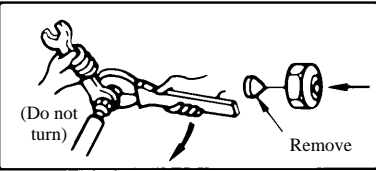
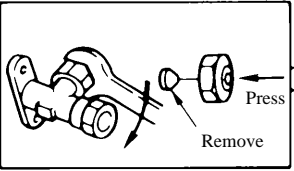
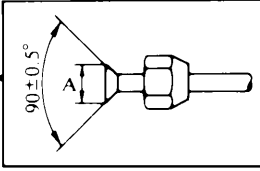
Indoor unit side	Outdoor unit side	
		
<ul style="list-style-type: none"> Remove the flared nuts. (on both liquid and gas sides) 	<ul style="list-style-type: none"> Remove the flared nuts. (on both liquid and gas sides) 	<ul style="list-style-type: none"> Install the removed flared nuts to the pipes to be connected, then flare the pipes.

Dimension A	
Liquid side	(φ6.35): 9-9.5 dia
Gas side	(φ9.52): 13.2-14 dia
	(φ12.7): 16.2-17 dia

(2) Connection of refrigerant piping

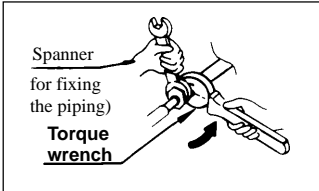
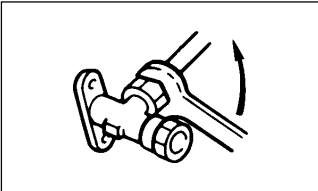
Indoor unit side	Outdoor unit side
<ul style="list-style-type: none"> Connect firmly gas and liquid side pipings by Torque wrench.  <ul style="list-style-type: none"> Specified torquing value: <p>Liquid side (ø6.35) : 15.7~19.6N·m (1.6~2kgf·m) Gas side (ø9.52) : 29.4~39.2N·m (3.0~4.0kgf·m) Gas side (ø12.7) : 39.2~49.0N·m (4.0~5.0kgf·m)</p>	<ul style="list-style-type: none"> Connect firmly gas and liquid side pipings by Torque wrench.  <ul style="list-style-type: none"> Specified torquing value: <p>Liquid side (ø6.35) : 15.7~19.6N·m (1.6~2kgf·m) Gas side (ø9.52) : 29.4~39.2N·m (3.0~4.0kgf·m) Gas side (ø12.7) : 39.2~49.0N·m (4.0~5.0kgf·m)</p> <ul style="list-style-type: none"> Use one more spanner to fix the valve.

- Always use a Torque wrench and back up spanner to tighten the flare nut.

(3) Air purge

- Tighten all flare nuts in the pipings both indoor and outside wall so as not to cause leak.
- Connect service valve, charge hose, manifold valve and vacuum pump as is illustrated below.
- Open manifold valve handle Lo to its full width, and perform vacuum or evacuation.

Continue the vacuum or evacuation operation for 15 minutes or more and check to see that the vacuum gauge reads - 0.1 MPa (- 76 cmHg).
- After completing vacuum operation, fully open service valve (Both gas and liquid sides) with hexagon headed wrench.
- Check for possible leakage of gas in the connection parts of both indoor and outdoor.

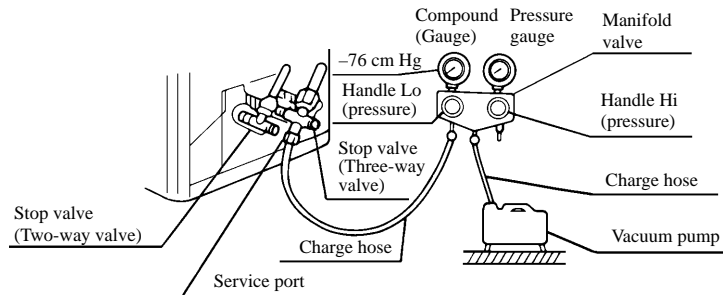

Additional refrigerant charge

When refrigerant piping exceeds 5m(50:7m) conduct additional refrigerant charging after refrigerant sweeping.

A mount of additional charge per meter: 20 g/m

Example of additional charge amount calculation

Calculate the additional charge amount, when the piping length is 10 m.

$$(10 - 5) \text{ m} \times 20\text{g/m} = 100\text{g} \quad \boxed{100\text{g for additional charge amount}}$$

(4) Insulation of connecting portion

- (a) Cover the connecting portion of the refrigerant piping with the pipe cover and seal them.

If neglecting to do so, moisture occurs on the piping and water will drip out.

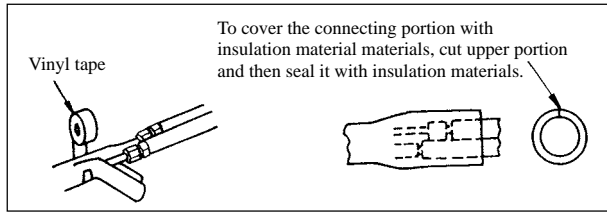

- (b) Finishing and fixing
 - (i) Tie up the piping with wrapping tape, and shape it so that it conforms to which the pipe is attached.
 - (ii) Fix them with clamps as right figure.

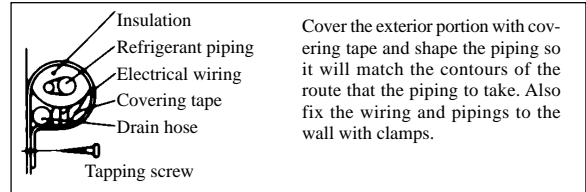

1.5.5 Test run

- (1) Conduct trial run after confirming that there is no gas leaks.
- (2) When conducting trial run set the remote controller thermostat to continuous operation position. However when the power source is cut off or when the unit's operation switch is turned off or was turned to fan operation position, the unit will not go into operation in order to protect the compressor.
- (3) Insert in electric plug into the electric outlet and make sure that it is not loose.
 - (a) When there is something wrong with the electric outlet and if the insertion of the electric plug is insufficient, there may occur a burn out.
 - (b) It is very important to be careful of above when plugging in the unit to an already furnished electrical outlet.
- (4) Explain to the customer on the correct usage of the air conditioner in simple layman's terms.
- (5) Make sure that drain flows properly.
- (6) **Standard operation data**

Item		Model	SRK25GZ-L1	SRK35GZ-L1	SRK50Z-L
High pressure MPa (kgf/cm ²)	Cooling		-	-	-
	Heating		1.76~1.96 (18~20)	1.76~1.96 (18~20)	2.06~2.25 (21~23)
Low pressure MPa (kgf/cm ²)	Cooling		0.39~0.49 (4~5)	0.39~0.49 (4~5)	0.29~0.49 (3~5)
	Heating		-	-	-
Temp. difference between suction air and discharge air (deg)	Cooling		10~13	10~13	11~13
	Heating		16~19	16~19	24~26
Running current (A)	Cooling		4.8	6.3	10.2
	Heating		5.8	7.7	11.5

Note (1) The data are measured at following conditions
 Ambient air temperature
 Indoor side: Cooling ... 27°C DB, 19°C WB, Heating ... 20°C DB
 Outdoor side: Cooling ... 35°C DB, 24°C WB, Heating ... 7°C DB, 6°C WB

1.5.6 Precautions for wireless remote controller installation and operation

(1) Wireless remote controller covers the following distances:

(a) When operating facing the air conditioner:

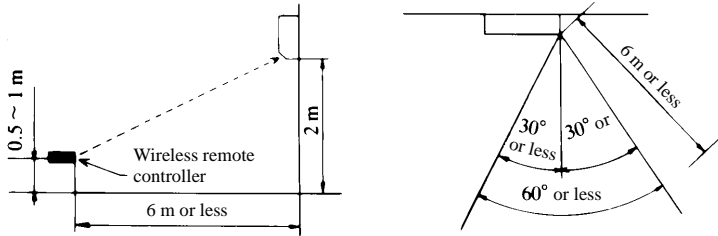

- Notes (1) The remote controller is correctly facing the sensing element of the air conditioner when being manipulated.
 (2) The typical coverage is indicated (in the left illustration). It may be more or less depending on the installation.
 (3) The coverage may be less or even nil. If the sensing element is exposed to strong light, such as direct sunlight, illumination, etc., or dust is deposited on it or it is used behind a curtain, etc.

(b) When manipulating the remote controller mounted on a wall:

Make sure that it works normally (i.e., transmission/reception signal is audible) before mounting.

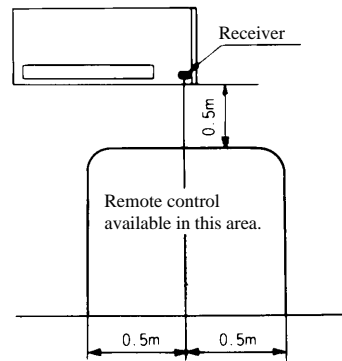

1.6 MAINTENANCE DATA

1.6.1 Trouble shooting

(1) Trouble shooting to be performed prior to exchanging PCB, (Printed circuit board) [Common to all models]

All the models described in this chapter are controlled by a microcomputer. When providing maintenance service to customers it is necessary to understand the function controlled by a micro computer thoroughly, so as not to mistakenly identify correct operations as mis-operations. It is also necessary to perform the following simple checks before conducting detailed checks or exchanging printed circuit board.

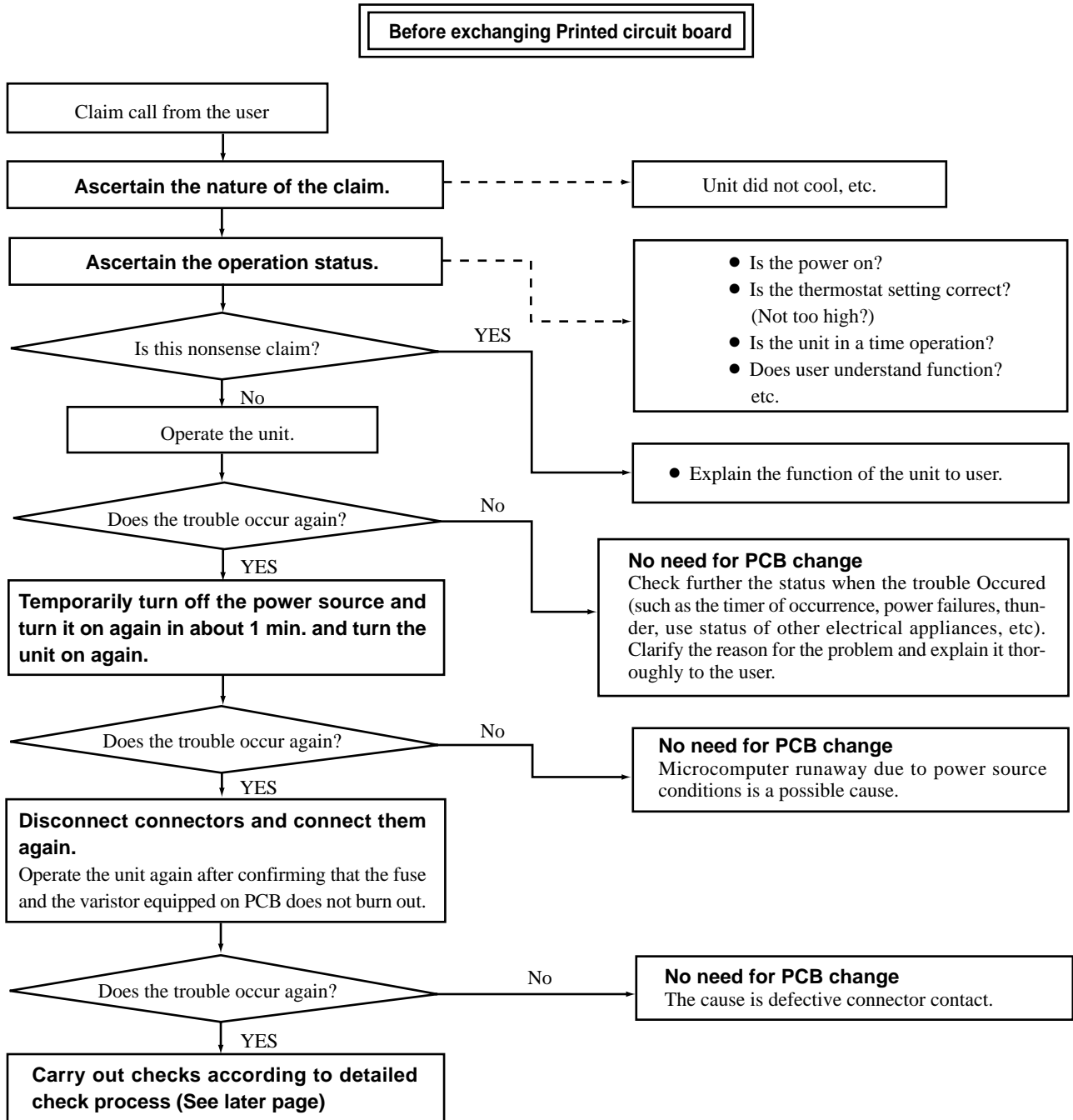

(2) Self diagnosis display on indoor unit

		Trouble	Cause	Conditions of flashing
<p>Outdoor unit LED</p> <p>⇨</p> <p>OFF</p> <p>OFF</p> <p>OFF</p>	<p>TIMER lamp ON</p> <p>1 time flash</p> <p>2 time flash</p> <p>6 time flash</p>	Heat exchanger thermistor error	<ul style="list-style-type: none"> Broken heat exchanger thermistor wire, connector poor connection 	When heat exchanger sensor temperature of -20°C or under continued for more than 3 minutes while operation is stopped. (This is not displayed during operation.)
		Room temperature thermistor error	<ul style="list-style-type: none"> Broken room temperature thermistor wire, connector poor connection 	When room temperature sensor temperature of -20°C or under continued for more than 3 minutes while operation is stopped. (This is not displayed during operation.)
		Indoor fan motor error	<ul style="list-style-type: none"> Defective fan motor, connector poor connection 	When air conditioner is operating and indoor fan motor is turned ON, indoor fan motor speed of 300 rpm or under continued for more than 30 seconds. (Air conditioner stops.)
<p>TIMER lamp</p> <p>⇨</p> <p>OFF</p> <p>OFF</p> <p>OFF</p>	<p>RUN lamp keeps flashing</p> <p>1 time flash</p> <p>2 time flash</p> <p>4 time flash</p>	External temperature thermistor error	<ul style="list-style-type: none"> Broken outdoor thermistor wire, connector poor connection 	When outdoor temperature thermistor temperature of -40°C or under continued for more than 3 seconds while operation is stopped. (This is not displayed during operation.)
		Outdoor unit heat exchanger thermistor error	<ul style="list-style-type: none"> Broken heat exchanger thermistor wire, connector poor connection 	When heat exchanger entrance thermistor temperature of -50°C or under continued for more than 3 seconds while operation is stopped. (This is not displayed during operation.)
		Discharge pipe (Comp.dome) thermistor error	<ul style="list-style-type: none"> Broken discharge pipe (Comp. dome) thermistor wire, connector poor contact 	When outdoor revolution speed of 0 rps continued for 3 minutes and then broken wire signal has been transmitted by discharge pipe (Comp. dome) thermistor data for more than 10 seconds. (Compressor stops.)
<p>RUN lamp ON</p> <p>1 time flash</p> <p>2 time flash</p> <p>3 time flash</p> <p>5 time flash</p> <p>6 time flash</p> <p>2 time flash</p>	<p>RUN lamp ON</p> <p>1 time flash</p> <p>2 time flash</p> <p>3 time flash</p> <p>5 time flash</p> <p>6 time flash</p> <p>2 time flash</p>	Current cut	<ul style="list-style-type: none"> Compressor lock, open phase on compressor output terminals, shortcircuit on power transistor. 	When converter output current which exceeds setting value is detected. (Compressor stops.)
		Outdoor unit error	<ul style="list-style-type: none"> Broken power transistor, broken compressor wire Discharge pipe thermistor poor contact. 	When input current value which is lower than setting value continued for more than 3 minutes. (Compressor stops.)
		Current safe stop	<ul style="list-style-type: none"> Overload operation, overcharge, compressor lock 	When inverter revolution speed is lower than setting value, when current safe function is actuated. (Compressor stops.)
		Compressor overheat	<ul style="list-style-type: none"> Gas shortage, defective discharge pipe (Comp. dome) thermistor, closed service valve 	When discharge pipe (Comp. dome) thermistor value exceeds setting value. (Compressor stops.)
		Serial signal transmission error	<ul style="list-style-type: none"> Power supply problem Broken signal wire, defective indoor/outdoor unit PCB 	Indoor unit controller ↔ Outdoor unit controller signals have not been transmitted for more than 10 seconds. (Compressor stops.)
<p>RUN lamp 2 time flash</p>	<p>RUN lamp 2 time flash</p>	Rotor lock	<ul style="list-style-type: none"> Compressor defective Outdoor unit circuit board defective 	When the position of the magnetic pole of the compressor motor cannot be properly detected.

Note (1) SRK502Z-L only

(3) Inspection procedures corresponding to detail of trouble

Thermistor error

[Broken thermistor wire, connector poor connection]

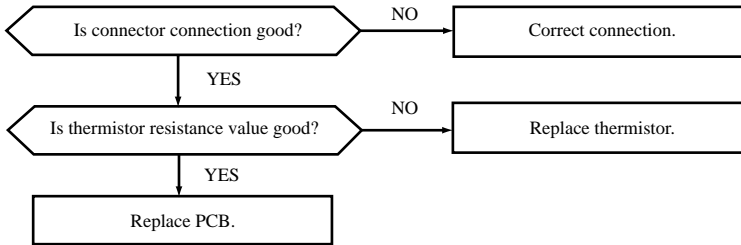

◆ **Discharge pipe (Comp. dome) thermistor temperature characteristics**

Temperature (°C)	Resistance (kΩ)	Temperature (°C)	Resistance (kΩ)
0	164	70	8.7
5	127	75	7.3
10	99	80	6.2
15	78	85	5.3
20	62	90	4.5
25	50	95	3.9
30	40	100	3.3
35	32	105	2.9
40	26	110	2.5
45	21	115	2.2
50	17	120	1.9
55	14	125	1.6
60	12	130	1.4
65	10	135	1.3

◆ **Thermistor temperature characteristics (Room temperature, indoor unit heat exchanger temperature, outdoor unit heat exchanger temperature, external temperature)**

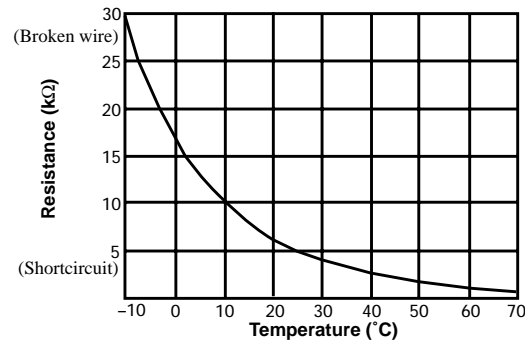

Current cut

[Open phase on compressor output terminal, compressor lock]

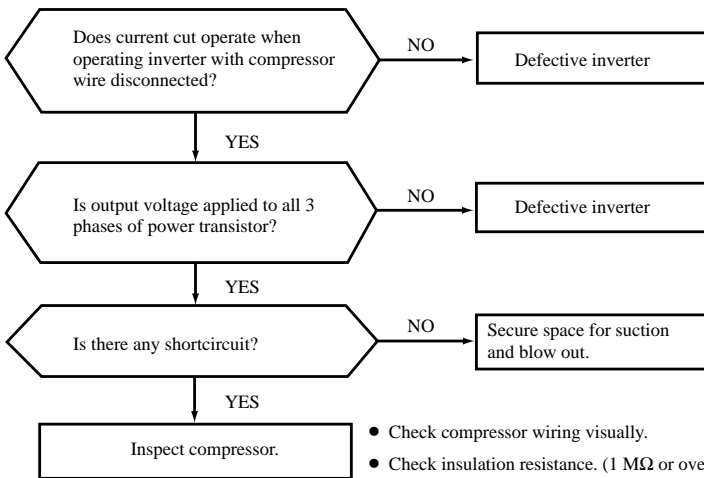

- Check compressor wiring visually.
- Check insulation resistance. (1 MΩ or over)
- Check coil wire resistance. (Few Ω)

— If check results are normal, compressor is locked.

Outdoor unit error [Broken power transistor
broken compressor wire]

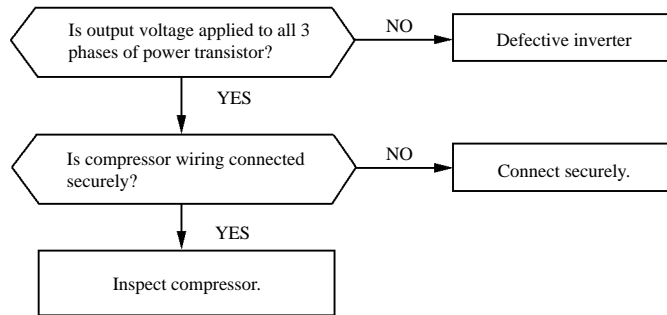

Current safe stop [Overload operation, compressor lock, overcharge]

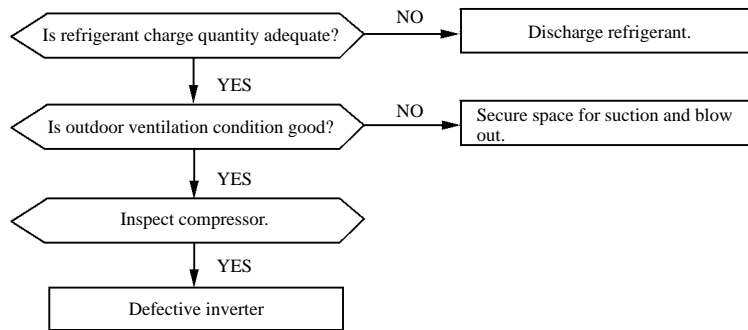

Compressor overheat [Gas shortage, defective discharge pipe (Comp. dome) thermistor]

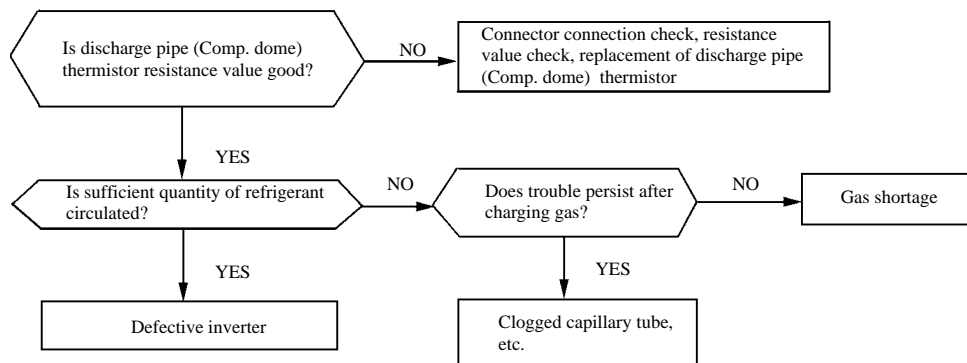

Serial signal transmission error

[Wiring error including power cable, defective indoor/outdoor unit PCB, error on power supply system]

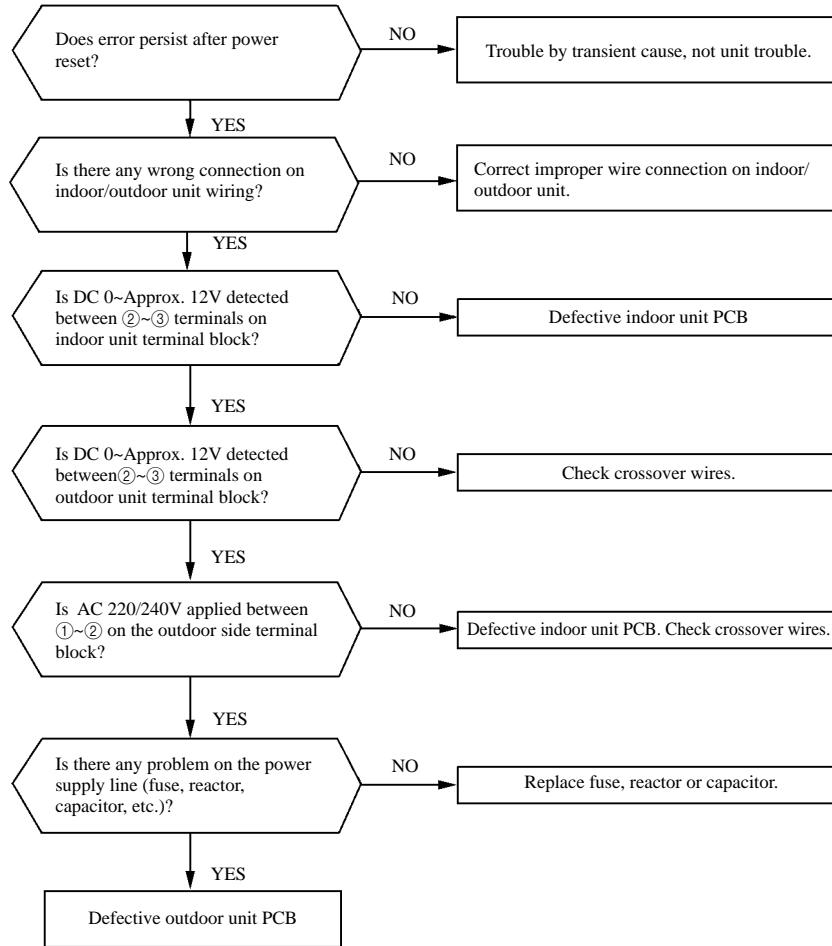

Indoor fan motor error

[Defective fan motor, defective PCB]

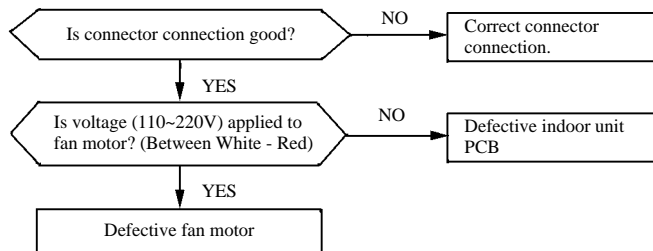

Rotor lock

[Compressor defect, outdoor unit circuit defect]

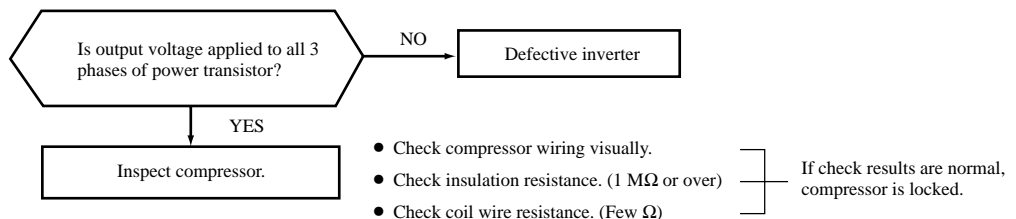

(4) Phenomenon observed after shortcircuit, wire breakage on thermistor.

(a) Indoor unit

Sensor	Operation mode	Phenomenon	
		Shortcircuit	Broken wire
Room temperature thermistor	Cooling	Release of continuous compressor operation command	Continuous compressor operation command is not released.
	Heating	Continuous compressor operation command is not released.	Release of continuous compressor operation command
Heat exchanger thermistor	Cooling	System can be operated normally.	Continuous compressor operation command is not released. (Anti-frosting)
	Heating	High pressure control mode (Inverter stop command)	Hot keep (Indoor fan stop)

(b) Outdoor unit

Thermistor	Operation mode	Phenomenon	
		Shortcircuit	Broken wire
Heat exchanger pipe thermistor	Cooling	System can be operated normally.	System can be operated normally.
	Heating	Defrosting is not performed.	Defrosting is performed for 10 minutes at approx. 1 hour.
External temperature thermistor	Cooling	System can be operated normally.	
	Heating	Defrosting is not operated.	Defrosting is performed for 10 minutes at intervals of approx. 1 hour.
Discharge pipe (Comp. dome) thermistor	All modes	Compressor overload protection is disabled. (Can be operated.)	Compressor stop (There is no inverter output.)

(5) How to make sure of remote controller

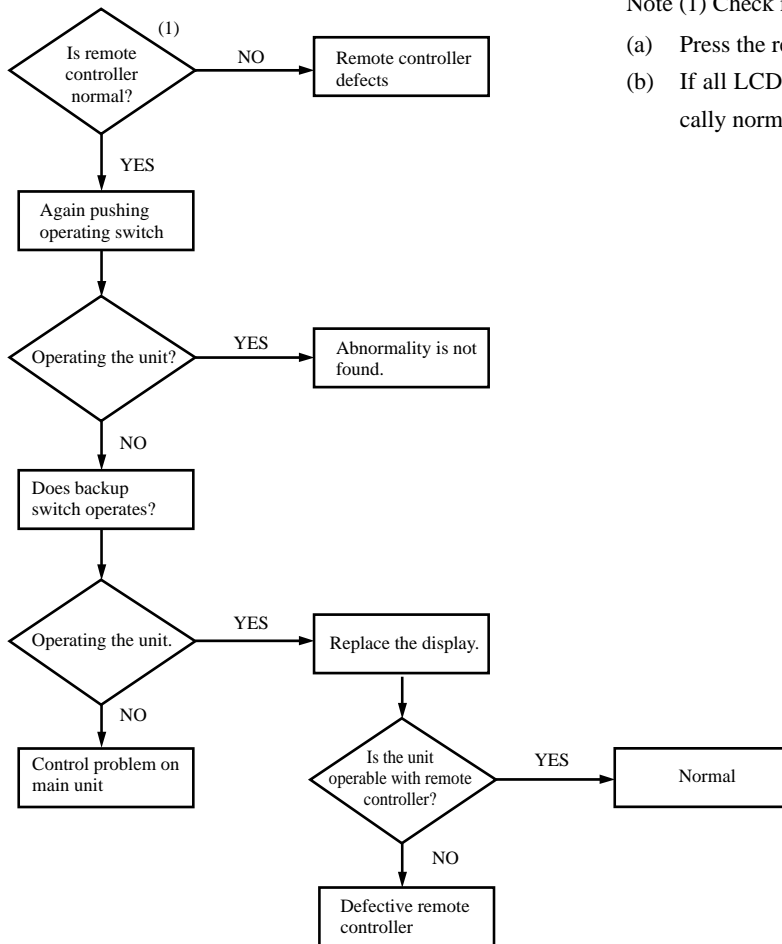

Note (1) Check method of remote controller

- (a) Press the reset switch of the remote controller.
- (b) If all LCD are displayed after zero (0) display, it is basically normal.

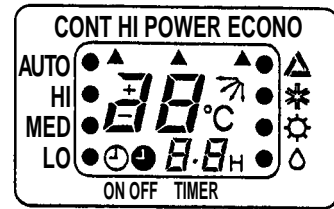

(6) Inspection procedures of indoor electrical equipment

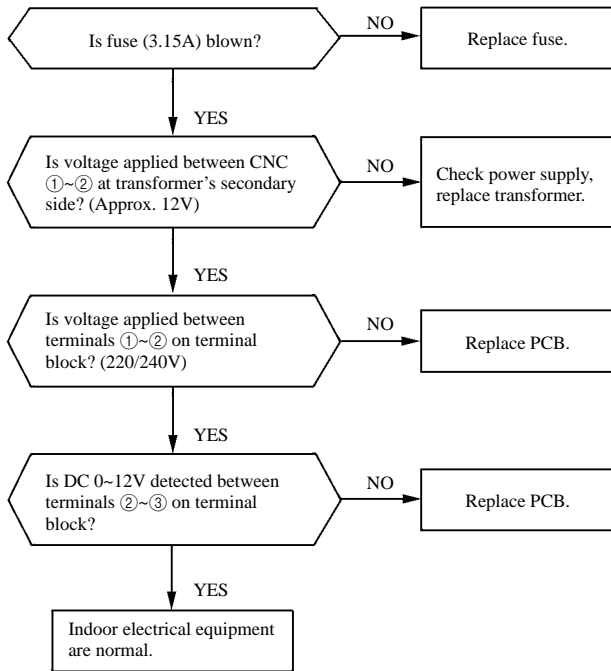

Notes (1) Since the communication timing signal is transmitted only when the 52C is turned ON, check it under the operating condition.

(2) Check the voltage on the terminal block.

- Power supply: Between ①~② (AC 220/240V)

- Signal: Between ②~③ (Changing between DC 0~Approx. 12V)

(7) Inspection procedures of inverter assembly

When the inverter is judged to be defective as a result of diagnosis of the item (2) above, inspect the inverter assembly as follows.)

(a) Diagnosis procedure (For further details, refer to the Inspection points of outdoor unit on the next page.)

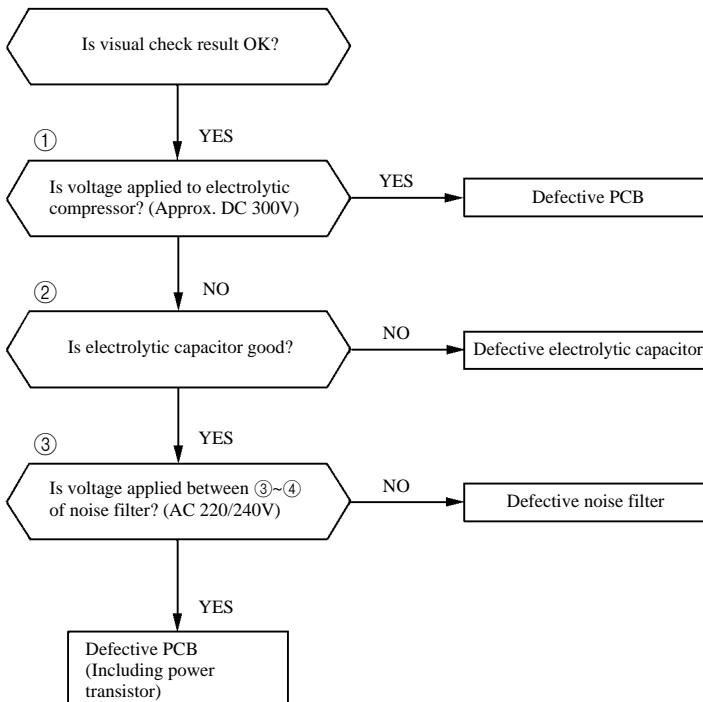

Checks ① and ③ must be made under the operating condition.

Before checking ②, make sure to turn power off, discharge electricity from the capacitor and check the residual voltage (10V or less) with a tester for safety.

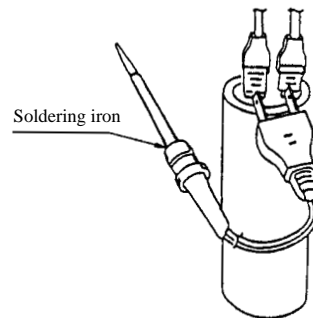

◆ Check point of outdoor unit (SRC35GZ-L1)

◆ Inspection of noise filter

- Check the voltage between terminals ③-④.

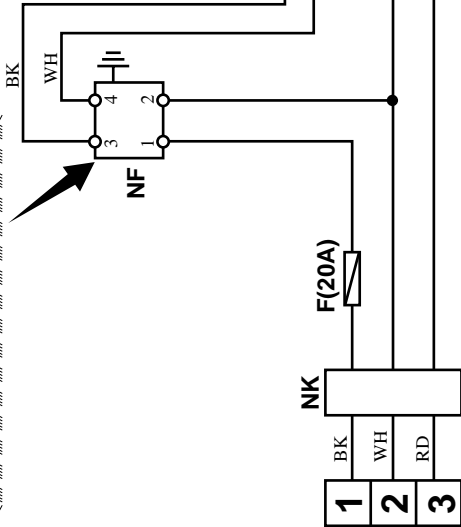

◆ Inspection of input to PCB

- Check the voltage between terminals ①-② on the terminal block. (It is normal if AC220/240V is detected.)
- Fuse check: it is normal if it is conductive:

◆ Inspection of serial signal

- Check the voltage between terminals ②-③ on the terminal block. (It is normal if the needle swings in the range of DC 0~Approx.12V)

Color symbol

BK	Black
BR	Brown
Y	Yellow
RD	Red
V	Violet
WH	White
Y/GN	Yellow/Green

◆ Inspection of capacitor

Check the charging characteristics with a tester. (Needle should swing and return slowly. Change the polarity and check again. If the needle returns, it is normal.)

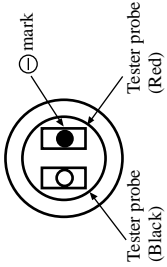

◆ Inspection of reactor conductivity

Remove the connector and check for conductivity. It must be conductive.

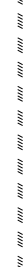

Tester probe (Black)

Tester probe (Red)

CM

NK

RD WH BK

U V W

Power Transistor

Check lamp

RL

Printed circuit board (Including power transistor)

CND

Th5

Th6

Th7

CNB

20S

FMO

CNC

Y/GN

Approx. DC 300V

Approx. DC 300V

Approx. DC 300V

Approx. DC 300V

Approx. DC 300V

Approx. DC 300V

Approx. DC 300V

Approx. DC 300V

Approx. DC 300V

Approx. DC 300V

Approx. DC 300V

Approx. DC 300V

Approx. DC 300V

Approx. DC 300V

Approx. DC 300V

Approx. DC 300V

Approx. DC 300V

Approx. DC 300V

Approx. DC 300V

Approx. DC 300V

Approx. DC 300V

◆ Inspection of power transistor output

Operation	Frequency(Hz)	Output voltage(V)
Cooling(HI POWER)	102	218
Cooling(Rating)	86	218
Heating(HI POWER)	110	218
Heating(Rating)	98	218

Note (1) The output voltage are reference values when the inverter has no load.

◆ Inspection of resistance value of discharge pipe thermistor

Remove the connector and check the resistance value. See the section of Thermistor characteristics on page 40.

◆ Check point of outdoor unit (SRC502Z-L)

CAUTION – HIGH VOLTAGE
 High voltage is produced in the control box. Don't touch electrical parts in the control box for 5 minutes after the unit is stopped.

● Power source and serial signal inspection
 ① to ②: AC220/240V
 ② to ③: Normal if the voltage oscillates between DC 0 and approx. 12V

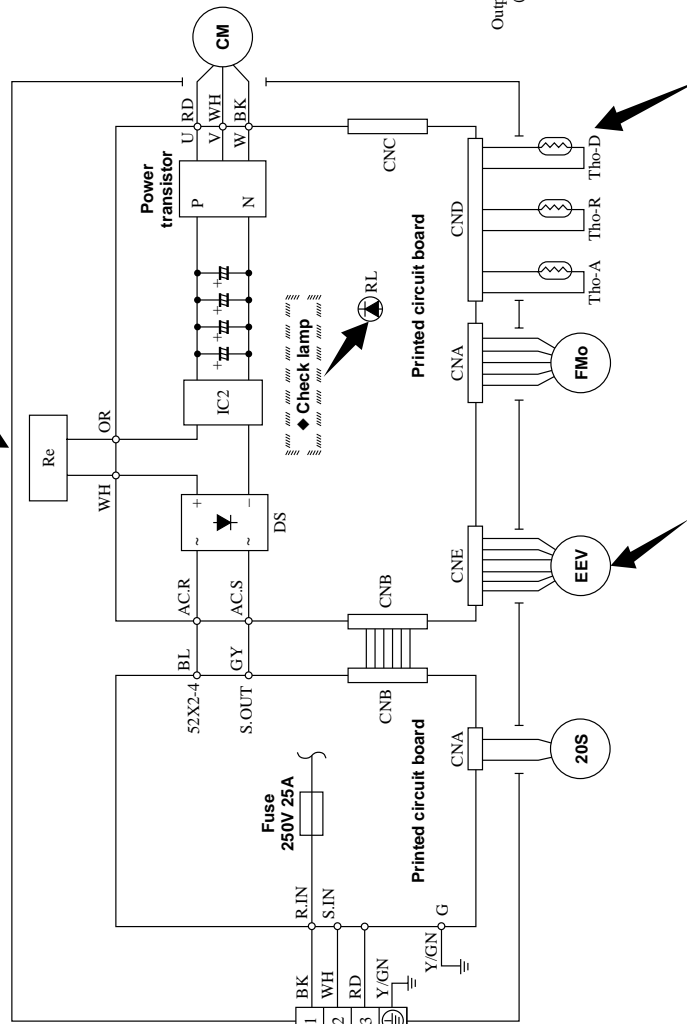

◆ Inspection of reactor conductivity
 Remove the connector and check for conductivity. It must be conductive.

◆ Inspection of resistance value of Comp. dome thermistor
 Remove the connector and check the resistance value. See the section of thermistor characteristics on page 40.

● Inspection of electronic expansion valve
 To test if there is voltage.
 (Voltage is only applied to the electronic expansion valve when the valve angle is being changed.)
 Red to white
 Red to Orange
 Brown to yellow
 Brown to blue
 Normal if there is approximately DC 5 V 10 seconds after the power supply is turned on.
 If the expansion valve does not operate as shown above, it is defective.

◆ Power transistor inspection procedure

[Use a tester with a needle indicator for the inspection. (Do not use a digital tester. Check in the AC 300 volt range.)]

(1) If there is a self-diagnosis display, inspect the compressor system (burns, wiring mistakes, etc.). If no problems are found, check the output of the power transistor.

(2) Output inspection procedure
 Disconnect the terminals for the compressor. If an output such as the one shown in the figure on the right can be measured, the power transistor and the circuit board for the outdoor unit are normal.

※ For about 50 seconds. After being switched on, there will be a delay of approximately one minute depending on the conditions.

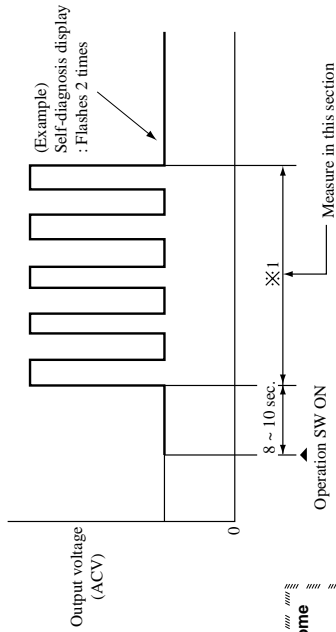

1.6.2 Servicing

(1) Evacuation

The evacuation is an procedure to purge impurities.....noncondensable gas, air, moisture from the refrigerant equipment by using a vacuum pump. Since the refrigerant R22 is very insoluble in water, even a small amount of moisture left in the refrigerant equipment will freeze, causing what is called water clogging.

- Evacuation procedure

- Check to ensure that there is no internal pressure in the unit. If there is an internal pressure, it should be relieved through the check joint.
- Connect the service hoses of the gauge manifold to the check joint of the gas & liquid piping.
- Connect a vacuum pump to the charge hose (A). Repeat evacuation in the following sequence.

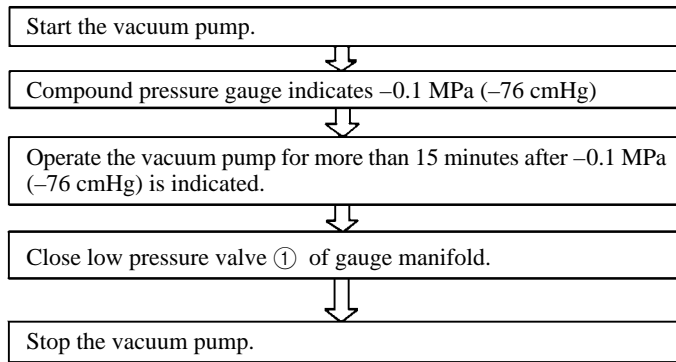

- Notes
- Do not use the refrigerant pressure to expel air.
 - Do not use the compressor for evacuation.
 - Do not operate the compressor in the vacuum condition.

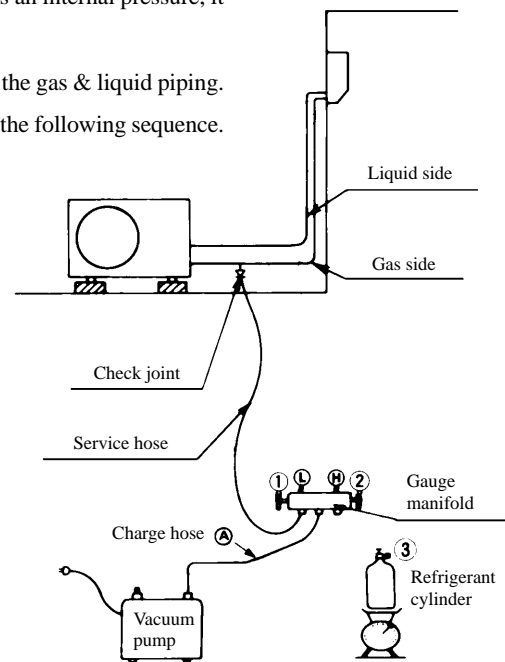

(2) Refrigerant charge

- Discharge refrigerant entirely from the unit and evacuate the unit.

Note: Addition of refrigerant without evacuation is unreasonable, because it will result in low charge or overcharge.
- Keep the gauge manifold and connect a refrigerant cylinder to the unit.
- Record the weight of the refrigerant cylinder on the balance. This is necessary for making sure of the charged refrigerant amount.
- Purge air from the charge hose (A)

Firstly loose the connecting portion of the charge hose (A) at the gauge manifold side and open the valve (③) for a few seconds, and then immediately retighten it after observing that gas is blow out from the loosened portion.
- Open the valve (①) and (③) after discharging air from the charge hose (A), then the gas refrigerant begins flowing from the cylinder into the unit. Be sure to erect the refrigerant cylinder upright to let gas refrigerant flow into the unit.
- When refrigerant has been charged into the system to some extent, **refrigerant flow becomes stagnant, when that happens, start the compressor in cooling cycle until the unit is filled with gas to the specified weight.**
- Making sure of the refrigerant amount, close the valve (③)
- Disconnect the charge hose from the unit. Cover the valve ports of the refrigerant piping with caps and tighten them securely.
- Check for gas leakage applying a gas leak detector along the piping line.
- Start the air conditioner and make sure of its operating condition.....high side and low side pressures and temperature difference between suction air and outlet air.

Model SRK502Z-L

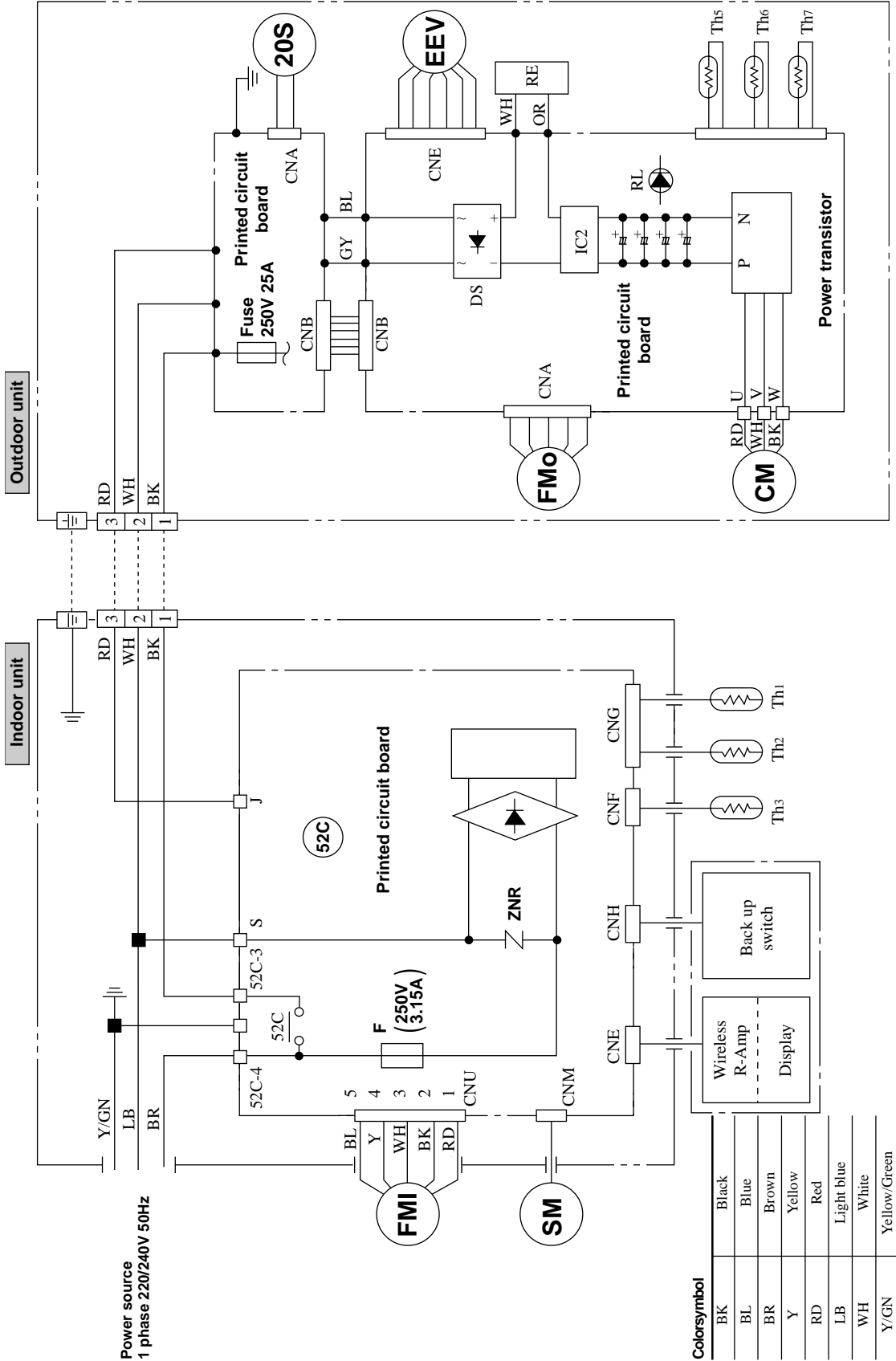

Colorsymbol

BK	Black
BL	Blue
BR	Brown
Y	Yellow
RD	Red
LB	Light blue
WH	White
Y/GN	Yellow/Green

1.4 OUTLINE OF OPERATION CONTROL BY MICROCOMPUTER

(1) Remote control switch

Remote control switch

Models All models

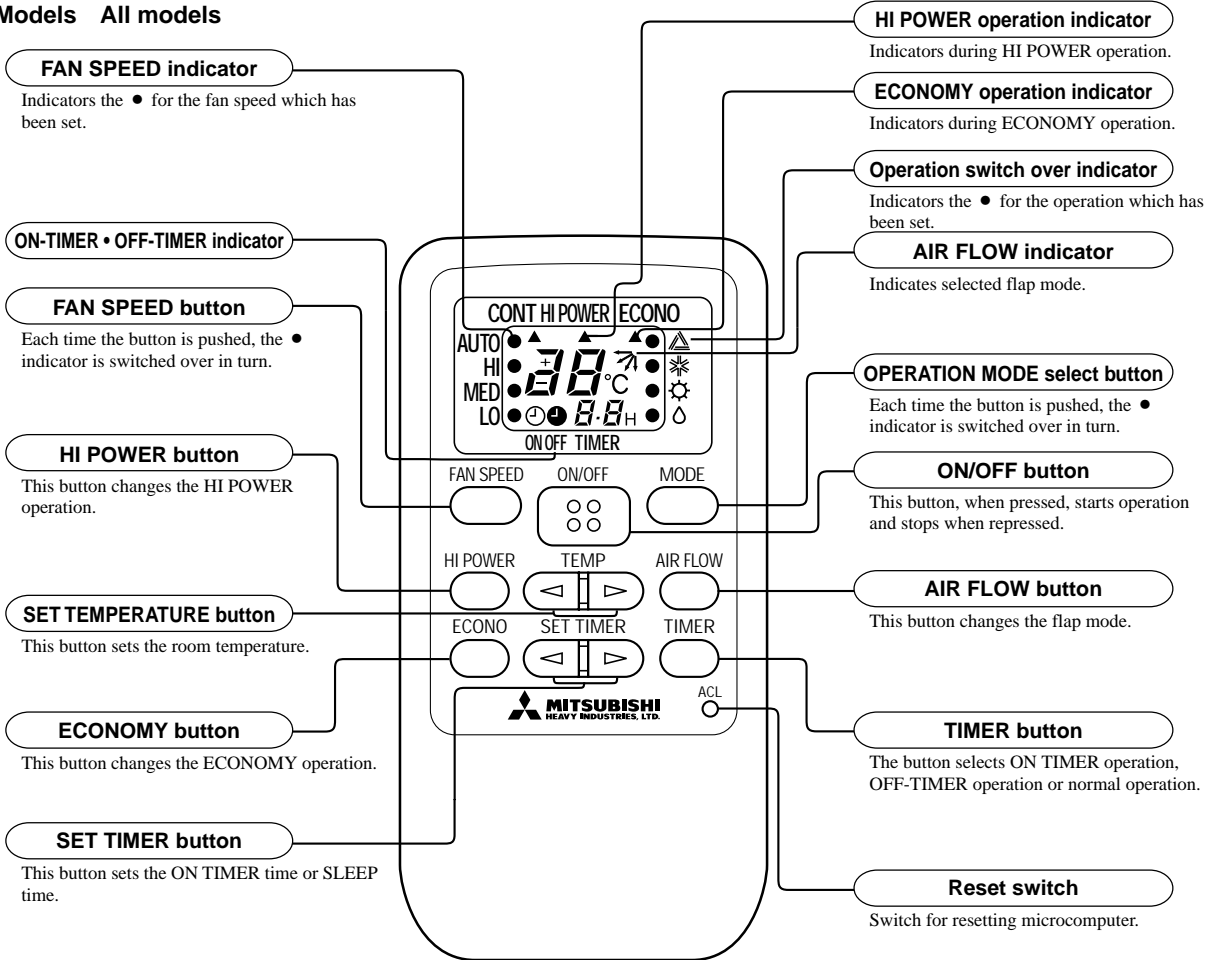

• Above figure shows all indications for the purpose of explanation, but practically only the pertinent parts are indicated.

Indoor unit indicator

Model SRK25GZ-L1

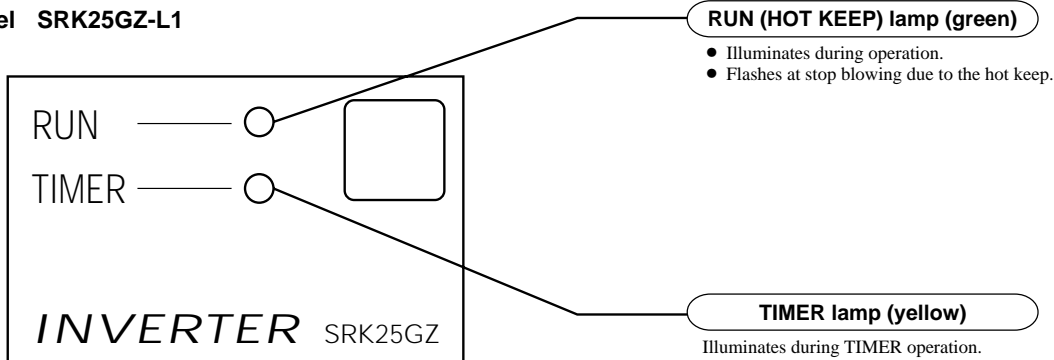

1.5 APPLICATION DATA



SAFETY PRECAUTIONS

- Please read these “Safety Precautions” first then accurately execute the installation work.
- Though the precautionary points indicated herein are divided under two headings, **⚠WARNING** and **⚠CAUTION**, those points which are related to the strong possibility of an installation done in error resulting in death or serious injury are listed in the **⚠WARNING** section. However, there is also a possibility of serious consequences in relationship to the points listed in the **⚠CAUTION** section as well. In either case, important safety related information is indicated, so by all means, properly observe all that is mentioned.
- After completing the installation, along with confirming that no abnormalities were seen from the operation tests, please explain operating methods as well as maintenance methods to the user (customer) of this equipment, based on the owner’s manual. Moreover, ask the customer to keep this sheet together with the owner’s manual.

WARNING

- This system should be applied to places as households, residences and the like. Application to inferior environment such as engineering shop could cause equipment malfunction.
- Please entrust installation to either the company which sold you the equipment or to a professional contractor. Defects from improper installations can be the cause of water leakage, electric shocks and fires.
- Execute the installation accurately, based on following the installation manual. Again, improper installations can result in water leakage, electric shocks and fires.
- For installation, confirm that the installation site can sufficiently support heavy weight. When strength is insufficient, injury can result from a falling of the unit.
- For electrical work, please see that a licensed electrician executes the work while following the safety standards related to electrical equipment, and local regulations as well as the installation instructions, and that only exclusive use circuits are used.
Insufficient power source circuit capacity and defective installment execution can be the cause of electric shocks and fires.
- Accurately connect wiring using the proper cable, and insure that the external force of the cable is not conducted to the terminal connection part, through properly securing it improper connection or securing can result in heat generation or fire.
- Take care that wiring does not rise upward, and accurately install the lid/service panel. It’s improper installation can also result heat generation or fire.
- When setting up or moving the location of the air conditioner, do not mix air etc. or anything other than the designated refrigerant (R22) within the refrigeration cycle.
Rupture and injury caused by abnormal high pressure can result from such mixing.
- Always use accessory parts and authorized parts for installation construction. Using parts not authorized by this company can result in water leakage, electric shock, fire and refrigerant leakage.
- Ventilate the work area when refrigerant leaks during the operation. 
- Coming in contact with fire, refrigerant could generate toxic gas.
- Confirm after the foundation construction work that refrigerant does not leak.
If coming in contact with fire of a fan heater, a stove or movable cooking stove, etc., refrigerant leaking in the room could generate toxic gas.

CAUTION

- Execute proper grounding. Do not connect the ground wire to a gas pipe, water pipe, lightning rod or a telephone ground wire.
Improper placement of ground wires can result in electric shock. 
- The installation of an earth leakage breaker is necessary depending on the established location of the unit.
No installing an earth leakage breaker may result in electric shock.
- Do not install the unit where there is a concern about leakage of combustible gas.
The rare even of leaked gas collecting around the unit could result in an outbreak of fire. 
- For the drain pipe, follow the installation manual to insure that it allows proper drainage and thermally insulate it to prevent condensation. Inadequate plumbing can result in water leakage and water damage to interior items.

1.5.2 Installation of indoor unit

(1) Installation of installation board

(a) Fixing of installation board

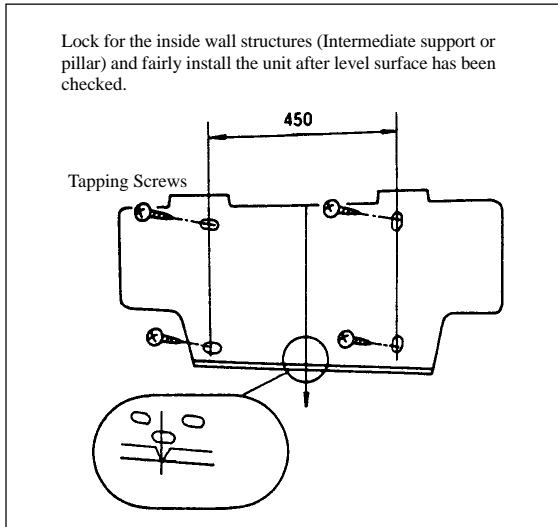

Adjustment of the installation board in the horizontal direction is to be conducted with four screws in a temporary tightened state.

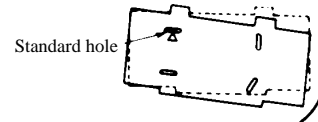

Adjust so that board will be level by turning the board with the standard hole as the center.

Fixing on concrete wall	
Use of nut anchor	Use of bolt anchor
<p>Bolt (M6 x 12)</p> <p>Mounting board</p>	<p>Nut (M6)</p> <p>Mounting board</p> <p>Max. 10</p>

(2) Drilling of holes and fixture sleeve (Option parts)

(a) Drill a hole with $\phi 65$ whole core drill

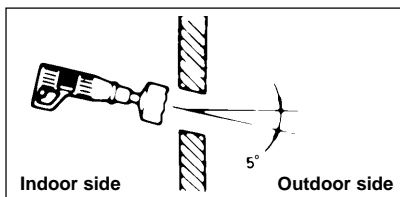

Note (1) Drill a hole with incline of 5 degree from indoor side to outdoor side.

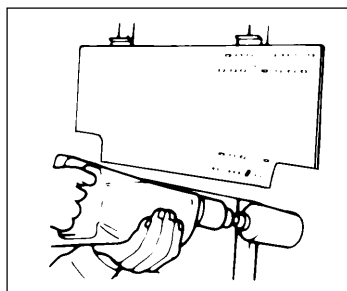

(b) Adjusting sleeve length

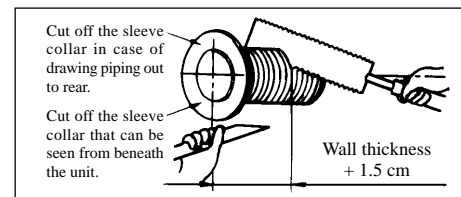

(c) Install the sleeve

(Inserting sleeve)

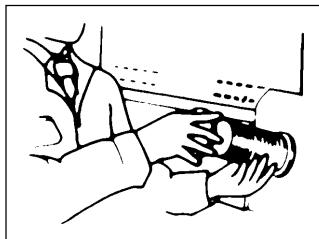

(*Sleeve + *Inclined + *Sealing plate)

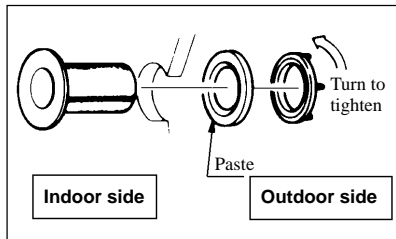

View of sleeve when installed

